

**SUPEROFFER**  
2024



EN

# XX GRIP



**PERFECT ON NEW HEXAGONS,  
EFFECTIVE ON DAMAGED BOLTS.**

**64/2024**

Valid till 31/03/2025



## DISCOVER THE NEWS 2024



*New*

**X-Grip range**  
**Page 4**



*New*

**Workshop furniture**  
**Page 10**



*New*

**Workbenches**  
**Page 14**



*New*

**Roller cabinets**  
**Page 18**



**Assortments**  
**Page 28**



**Maintenance suitcase**  
**Page 32**



**Portable storage**  
**Page 34**



**Screwdrivers**  
**Page 38**



**Hexagon keys and bits**  
**Page 41**

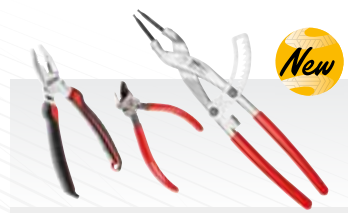

*New*

**Pliers**  
**Page 46**



**Wrenches**  
**Page 51**



*New*

**Ratchets and sockets**  
**Page 56**



**Pullers**  
**Page 61**



**Controlled tightening**  
**Page 62**



**Electrician scissors**  
**Page 65**



**Electrotechnics**  
**Page 66**



**Plumbing**  
**Page 68**



**Rivet pliers**  
**Page 69**



*New*

**Maintenance**  
**Page 70**



*New*

**Lighting**  
**Page 74**



*New*

**Automotive**  
**Page 76**



**Air tools and accessories**  
**Page 84**

**Look for  
ICONIC PRODUCT:  
the tools that make the difference!**





## X-GRIP RANGE

PERFECT ON NEW HEXAGON AND EFFECTIVE ON DAMAGED BOLT



**NUTS AND SCREWS WITH HEX HEAD**



**SOCKET HEAD SCREWS**



285 X



280 HX



235 X



280 X

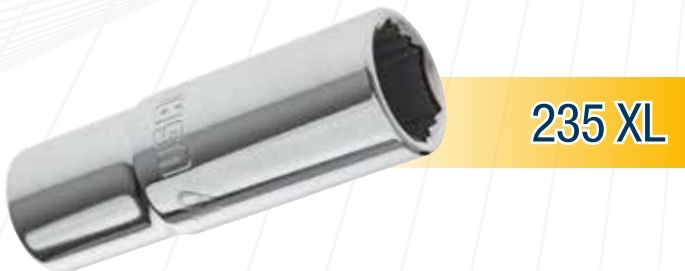

235 XL



660 X

### EXCLUSIVE PROFILE X-GRIP

Only USAG has the solution to unscrew very damaged nuts and bolts .

### PERFECT ON NEW HEXAGONS

If you are working on new hexagons, the X-Grip profile transmits more torque compared to a normal profile, avoiding damage to the hexagon surface.

# COMBINATION WRENCH 285 X

## INCLINED OPEN END

angled at 15° as regards to wrench axis.



## DOUBLE T SECTION

Excellent resistance to flexion.

## SPECIAL RING SHAPE

Ideal for operations on nuts difficult to reach.

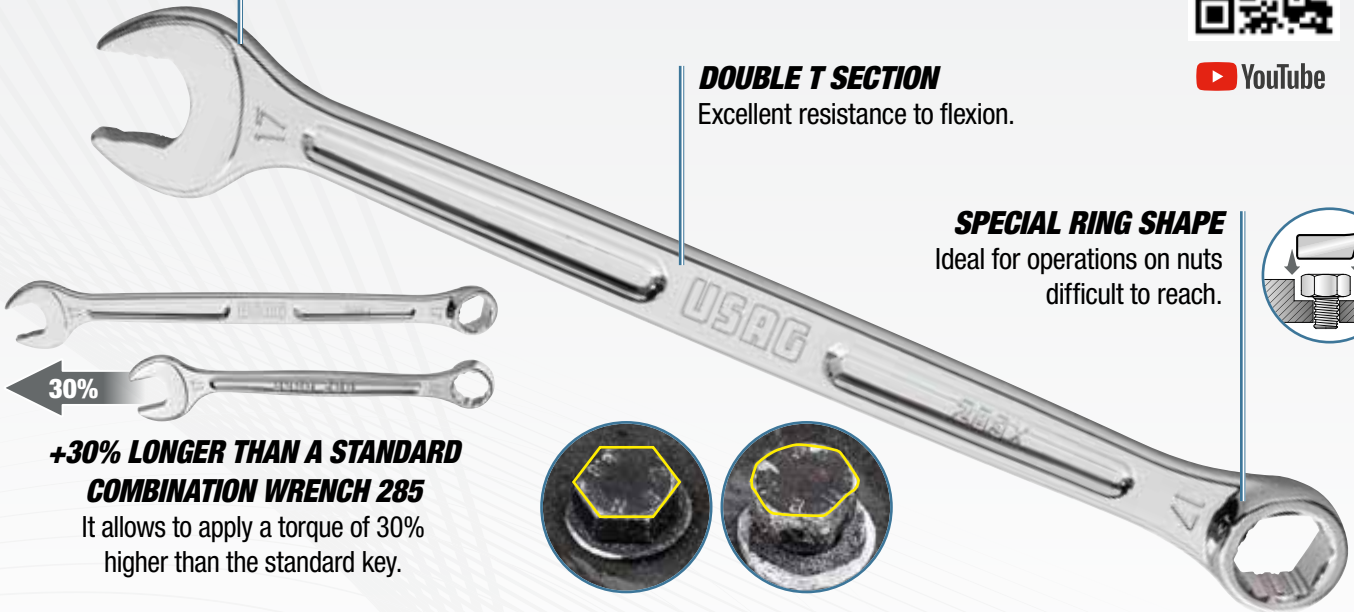
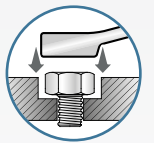

30%

## +30% LONGER THAN A STANDARD COMBINATION WRENCH 285

It allows to apply a torque of 30% higher than the standard key.

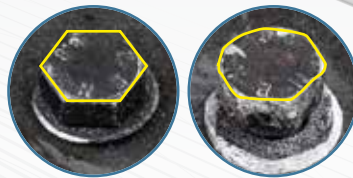

## SPECIAL PROFILES

- The internal profile of open/box end is designed to works on new hexagons and even on very damaged hexagons (up to 80% using the ring, 60% with the open end)



8

PIECES

285 X/B8

U02850950

Set of 8 combination wrenches with special profiles

- 285 X/8-10-11-12-13-14-17-19 mm.
- Supplied in a high strength fabric roll-up bag



8÷19 mm

12

PIECES

285 X/B12

U02850951

Set of 12 combination wrenches with special profiles

- 285 X/8-9-10-11-12-13-14-15-16-17-18-19 mm.



8÷19 mm

## SOCKETS 235 X

**SPECIAL CHROME VANADIUM STEEL**  
Chrome plated finish



YouTube



### BENEFITS OF X-GRIP PROFILE:

- Perfect grip on new or damaged hexagons, up to 80%
- It transmits more torque than a standard socket.
- No damage to new hexagon.



### MAGNETIC LOCKING SOCKET HOLDER 559 A

- Available with 3/8, 1/4, 1/2 clips
- Magnetic base protected by a rubber layer: not damage the surface
- 360° adjustable clips, to quickly identify the socket size



**235 1/2" X/SE12**  
U02350501

12  
PIECES



Set of 12 hexagonal sockets with special profile



10-11-12-13-14-  
15-16-17-18-19-  
22-24 mm



**235 1/4" X/SE10**  
U02350500

10  
PIECES



Set of 10 hexagonal sockets with special profile



5,5-6-7-8-9-10-  
11-12-13-14 mm

# ASSORTMENT WITH BITS 660 X AND SOCKETS 235 X



**23**  
PIECES

**1/4"**

**1/4"**



Socket-holder



**609 1/4" SKX**  
U06090004

134 g | mm | 120  
30  
60

## Assortment with special hexagonal sockets and bits

- Compact bimaterial box with soft-touch covering
- Metal closing clip
- Socket size engraved inside

DESCRIPTION	ITEM/SIZE	PCS.
Reversible ratchet with extension	237 1/4" SK	2
Hexagonal sockets with special profile	235 1/4" X 6-8-10-12-13	5
Bits for slot-head screws	660 0,5x4	1
Bits for PHILLIPS® screws	660 PH 2	1
Bits for Pozidriv®- Supadriv® screws	660 PZ 2	1
Socket-holder bit	660 Q 1/4"	1
Bits for TORX® Tamper Resistant screws	660 STX T20-T25-T30-T40	4
Bits with special hexagonal profile	660 X 2-2,5-3-4-5-6-7-8	8

# ASSORTMENT WITH BITS 660 X



**2-2,5-3-4-5-6-7-8 mm**



**9**  
PIECES

**1/4"** Bit-holding socket

**660 X/B9**  
U06600100

110  
20  
mm | 105



## Set of bits with special profile

- Special hexagonal profile X-Grip: perfect grip on new or damaged hexagons recessed, up to 92%
- Special steel with phosphated finish
- Including 1/4-1/4" bit holding socket
- Supplied in a compact fabric pouch

DESCRIPTION	ITEM/SIZE	PCS.
Bits with special hexagonal profile	660 X 2-2,5-3-4-5-6-7-8	8
Bit-holding socket	684 1/4	1

# BITS 660 X

## EXCLUSIVE PROFILE X-GRIP

The special design of the grip bits allows you to grip the hexagons recessed in any condition: intact or completely damaged.

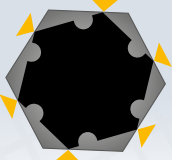

## DAMAGED SCREWS

When a screw with a hexagon socket-head is damaged, it is no more possible to unscrew it with normal hexagonal male keys.

The new 660 X grip bits allow to unscrew even screws extremely damaged, up to 98% of the hexagonal profile.





## HEXAGON KEYS 280 X AND 280 HX

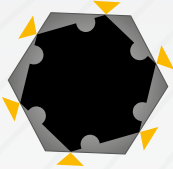

### EXCLUSIVE PROFILE X-GRIP

The special design of the grip bits allows you to grip the hexagons recessed in any condition: intact or completely damaged.



### DAMAGED SCREWS

When a screw with a hexagon socket-head is damaged, it is no more possible to unscrew it with normal hexagonal male keys.

Hexagon keys 280 X and 280 HX allow to unscrew even screws extremely damaged, up to 98% of the hexagonal profile.



**6**  
PIECES



YouTube

### 280 HX/SE6

U02802460

**Set of 6 angled hexagon keys with special profiles and bimaterial handgrip**

- 280 HX/2,5-3-4-5-6-8 mm.
- Ergonomic bimaterial handgrip with anti-slip coating
- Design studied for a safe grip during operations
- Highly alloyed special steel
- Zinc phosphate plated for high corrosion resistance

### 280 X/S9

U02800485

**Set of 9 angled hexagon keys with special profiles**

- 280 X/1,5-2-2,5-3-4-5-6-8-10 mm.
- It allows you to work on damaged screws even at an angle of 25°
- Highly alloyed special steel
- Zinc phosphate plated for high corrosion resistance
- Supplied with plastic holder

**9**  
PIECES



YouTube





# X-GRIP MODULES FOR YOUR ROLLER CABINET!

New

XL



52  
PIECES

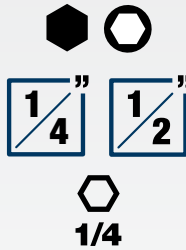

519 M 235X  
U05191065

Bi-colour foam module with assortment

DESCRIPTION	ITEM/SIZE	PCS.
Hexagonal sockets with special profile	235 1/2 X10-11-12-13-14-15-16-17-18-19-22-24	12
Hexagonal sockets with special profile	235 1/4 X 5,5-6-7-8-9-10-11-12-13-14	10
Long hexagonal sockets with special profile	235 1/2 XL 17-19-21	3
Extensions	236 1/2 125-250	2
Extensions	236 1/4 125-250	2
Reversible ratchet with sealed mechanism (certified IP51)	237 A 1/2	1
Reversible ratchet with sealed mechanism (certified IP51)	237 A 1/4	1
T-handle with sliding square drive	240 1/2 N	1
T-handle with sliding square drive	240 1/4	1
Universal joint	241 1/2	1
Universal joint	241 1/4	1
Set of 9 angled hexagon keys with special profiles X-Grip	280 X/S9 1,5-2-2,5-3-4-5-6-8-10	9
Bits with special hexagonal profile	660 X 2-2,5-3-4-5-6-7-8	8
Bit-holding socket	684 1/4	1

New

L

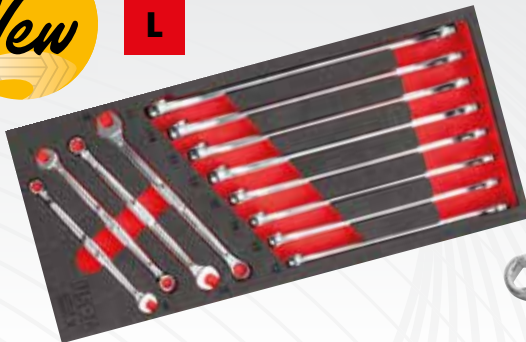

12  
PIECES



519 M 285X  
U05191063

Bi-colour foam module with assortment

- 285 X/8-9-10-11-12-13-14-15-16-17-18-19 mm.

New

L

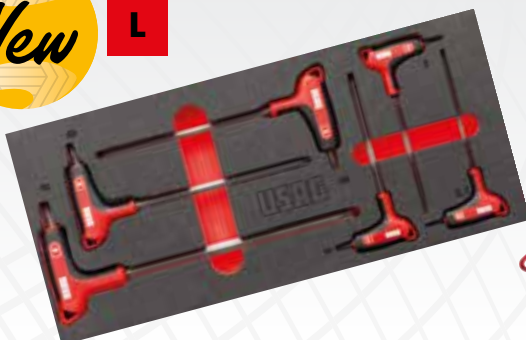

6  
PIECES

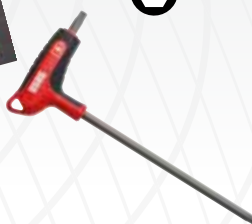

519 M 280HX  
U05191064

Bi-colour foam module with assortment

- 280 HX/2,5-3-4-5-6-8 mm.

Do you want to add more modules in your assortment?  
Go to page 31

**FURNITURE LINE START 516  
PROFESSIONAL WORKSTATION**



YouTube



**QUALITY OF  
START RANGE**



High resistance 35 mm slides with a load capacity up to 40 kg.  
Handles in high resistant ABS.

**WORKTOP, STEEL OR WOOD,  
LARGE AND DURABLE**



Depth: 600 mm.  
Static load capacity: 1000 Kg.

**COMPATIBLE WITH  
USAG MODULARITY**

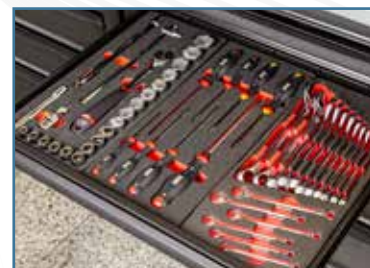

The drawers are compatible with the USAG foam modules or plastic trays system present in the Catalog.



**CHOOSE YOUR IDEAL LAY-OUT**  
Try it now: go to [start516-gb.usag.it](http://start516-gb.usag.it)

## Hooks, LED lamps, power strips and drawer on wheels included



DESCRIPTION	ITEM	PCS.
Base unit with 2 doors	516 SA/2T	1
Base unit with 6 drawers	516 SA/1T	1
Base unit with 7 drawers	516 SA/1T/7	1
START roller cabinet - 6 drawers (empty)	516 SA/16T	1
Base unit with bin and paper roll holder	516 SA/17T	1
Open drawer on wheels	516 SA/20T	4
Pegboard	516 SA/5T	8
Pegboard with power strip (3 SCHUKO plug and 2 USB doors)	516 SA/6T	2
Cabinet with 2 door	516 SA/3T/2	1
Cabinet with 1 door	516 SA/3T	1
LED lamps	516 SA/12	2
Top chest with tilting door	516 SA/4T	5
Rack for power tools	516 SA/4TP	1
Fitting kit	516 SA/14T	5
Raising support	516 SA/11T	6



**516 SA/CTA**  
U05160299



502 kg



↓ 2.000  
↗ 650



**516 SA/CTL**  
U05160300



502 kg



↓ 2.000  
↗ 650

**Steel top**  
1.450 mm - 516 AC/1  
2.175 mm - 516 AC/2  
**Corner kit**  
516 SA/19T

**Workshop furniture - steel top**  
• Supplied with 30 hooks (kit 516 SA/K1)

**Wooden top**  
1.450 mm - 516 SAL/1  
2.175 mm - 516 SAL/2  
**Corner kit**  
516 SA/18T

**Workshop furniture - wooden top**  
• Supplied with 30 hooks (kit 516 SA/K1)

2.100 mm      2.100 mm



## Hooks, LED lamps, power strips and drawer on wheels included

DESCRIPTION	ITEM	PCS.
Base unit with 7 drawers	516 SA/1T/7	1
Base unit with 6 drawers	516 SA/1T	1
Base unit with 2 doors	516 SA/2T	1
Base unit with bin and paper roll holder	516 SA/17T	1
Pegboard	516 SA/5T	7
Pegboard with power strip (3 SCHUKO plug and 2 USB doors)	516 SA/6T	1
Top chest with tilting door	516 SA/4T	4
LED lamps	516 SA/12	2
Open drawer on wheels	516 SA/20T	4
Fitting kit	516 SA/14T	4
Raising support	516 SA/11T	4



**516 SA/CBA**  
U05160297



529 kg



↓ 2.000  
↗ 650



**516 SA/CBL**  
U05160298



529 kg



↓ 2.000  
↗ 650

**Steel top**  
2.175 mm  
516 AC/2 (x2)  
**Corner kit**  
516 SA/19T

**Workshop furniture - steel top**  
• Supplied with 30 hooks (kit 516 SA/K1)

**Wooden top**  
2.175 mm  
516 SAL/2 (x2)  
**Corner kit**  
516 SA/18T

**Workshop furniture - wooden top**  
• Supplied with 30 hooks (kit 516 SA/K1)



**CHOOSE YOUR**  
Try it now: go to



**Hooks, LED lamps, power strips and drawer on wheels included**

DESCRIPTION	ITEM	PCS.
Base unit with 7 drawers	516 SA1T/7	1
Base unit with bin and paper roll holder	516 SA1T/7	1
Pegboard	516 SA5T	5
Pegboard with power strip (3 SCHUKO plug and 2 USB doors)	516 SA6T	1
Top chest with tilting door	516 SA/4T	3
Cabinet with 2 door	516 SA3T/2	1
START roller cabinet - 6 drawers (empty)	516 SA/16T	1
Rack for power tools	516 SA4TP	1
Open drawer on wheels	516 SA20T	2
LED lamps	516 SA/12	2
Fitting kit	516 SA14T	3
Raising support	516 SA11T	3



**516 SA/PRA**  
U05160295



342 kg



↔ 3.175  
↓ 2.000  
↙ 650

Steel top

2.175 mm - 516 AC/2

**Workshop furniture - steel top**

- Supplied with 30 hooks (kit 516 SA/K1)



**516 SA/PRL**  
U05160296



332 kg



↔ 3.175  
↓ 2.000  
↙ 650

Wooden top

2.175 mm - 516 SAL/2

**Workshop furniture - wooden top**

- Supplied with 30 hooks (kit 516 SA/K1)



**Hooks, LED lamps, power strips and drawer on wheels included**

DESCRIPTION	ITEM	PCS.
Base unit with 6 drawers	516 SA/1T	1
Base unit with 2 doors	516 SA/2T	1
Pegboard	516 SA5T	5
Pegboard with power strip (3 SCHUKO plug and 2 USB doors)	516 SA6T	1
Top chest with tilting door	516 SA/4T	3
Cabinet with 1 door	516 SA/3T	1
START roller cabinet - 6 drawers (empty)	516 SA/16T	1
Open drawer on wheels	516 SA20T	2
LED lamps	516 SA/12	2
Fitting kit	516 SA14T	3
Raising support	516 SA11T	3



**516 SA/STA**  
U05160293



295 kg



↔ 2.675  
↓ 2.000  
↙ 650

Steel top

2.175 mm - 516 AC/2

**Workshop furniture - steel top**

- Supplied with 30 hooks (kit 516 SA/K1)



**516 SA/STL**  
U05160294



284 kg



↔ 2.675  
↓ 2.000  
↙ 650

Wooden top

2.175 mm - 516 SAL/2

**Workshop furniture - wooden top**

- Supplied with 30 hooks (kit 516 SA/K1)

## IDEAL LAY-OUT

start516-gb.usag.it



### Hooks, LED lamps, power strips and drawer on wheels included

DESCRIPTION	ITEM	PCS.
Base unit with 6 drawers	516 SA/1T	1
Base unit with 2 doors	516 SA/2T	1
Pegboard	516 SA5T	3
Pegboard with power strip (3 SCHUKO plug and 2 USB doors)	516 SA6T	1
Top chest with tilting door	516 SA/4T	2
Cabinet with 1 door	516 SA/3T	1
Open drawer on wheels	516 SA20T	2
Fitting kit	516 SA14T	2
Raising support	516 SA11T	3



**516 SA/CA**  
U05160291



205 kg



mm

↔ 1.950  
↓ 2.000  
↙ 650

Steel top

1.450 mm - 516 AC/1

**Workshop furniture - steel top**

- Supplied with 30 hooks (kit 516 SA/K1)



**516 SA/CL**  
U05160292



197 kg



mm

↔ 1.950  
↓ 2.000  
↙ 650

Wooden top

1.450 mm - 516 SAL/1

**Workshop furniture - wooden top**

- Supplied with 30 hooks (kit 516 SA/K1)



DESCRIPTION	ITEM	PCS.
Base unit with 6 drawers	516 SA/1T	1
Base unit with 2 doors	516 SA/2T	1
START roller cabinet - 6 drawers (empty)	516 SA/16T	1
Raising support	516 SA11T	2



**516 SA/BCA**  
U05160289



200 kg



mm

↔ 2.175  
↓ 817  
↙ 500

Steel top

2.175 mm - 516 AC/2

**Workshop furniture - steel top**



**516 SA/BCL**  
U05160290



188 kg



mm

↔ 2.175  
↓ 817  
↙ 500

Wooden top

2.175 mm - 516 SAL/2

**Workshop furniture - wooden top**



## WORKBENCH SYSTEM 506 TOP RESISTANCE AND STABILITY



### ACCESSORIES

Compatible with 516 AC line  
(only 506 KA and KL models)



### LARGE DRAWERS

mounted on high quality slides



### SHEET-STEEL UPRIGHTS

thickness 1.2 mm,  
for maximum resistance



All models are available with  
worktop in steel (thickness 3 mm) or  
multilayer wood (thickness 30 mm)



All models have screw holes. You  
can fix the workbenches to the  
floor or place them side by side.

2.000 kg



**506 KA**  
U05060256

RAL 9005

**Workstation with sheet steel top**

- Galvanized sheet steel top (thickness 3 mm) with sides 37 mm
- Durable structure with 6 uprights
- Double fully opening drawers, with locking
- Metal sheet-steel doors with adjustable hinges
- Lower shelf included
- Possibility to hang 516 accessories in the lateral sides
- Arranged for ground fixing
- Static load capacity: 2000 kg
- Internal drawers dimension: 830x550x110 mm
- Internal compartments with doors dimension: 860x350x440 mm
- RAL 9005 painted steel
- Supplied disassembled

150 kg | 2.000 mm | 910 mm | 700 mm



2000 mm

2.000 kg



**506 KL**  
U05060246

RAL 9005

**Workstation with wooden top**

- Multilayer wooden top, thickness 30 mm
- Durable structure with 6 uprights
- Double fully opening drawers, with locking
- Metal sheet-steel doors with adjustable hinges
- Lower shelf included
- Possibility to hang 516 accessories in the lateral sides
- Arranged for ground fixing
- Static load capacity: 2000 kg
- Internal drawers dimension: 830x550x110 mm
- Internal compartments with doors dimension: 860x350x440 mm
- RAL 9005 painted steel
- Supplied disassembled

140 kg | 2.000 mm | 910 mm | 700 mm



2000 mm

# Workbenches



## 506 TAC

RAL 9005

STEEL

### Workbench with sheet steel top

- Galvanized sheet steel top (thickness 3 mm) with sides 37 mm
- Metal sheet-steel doors uprights and lower shelf, thickness 1,2 mm
- Side holes for fixing multiple benches side by side.
- Arranged for ground fixing
- 6 uprights for size 2 m
- Gap between 2 uprights: 864 mm
- Gap between lower shelf and worktop: 525 mm
- Internal drawer dimensions:
- L 1000 and L 2000: 830x550x110 mm
- L 1500: 1280x550x110 mm
- Supplied disassembled

CODE	DIMENSIONS LxDxH	Weight	N° drawers
U05060154	1046x700x910 mm	65 kg	1
U05060155	1500x700x910 mm	85 kg	1
U05060156	2000x700x910 mm	110 kg	2



## 506 TLC

RAL 9005

WOOD

### Workbench with wooden top

- Multilayer wooden top, thickness 30 mm
- Metal sheet-steel doors uprights and lower shelf, thickness 1,2 mm
- Side holes for fixing multiple benches side by side.
- Arranged for ground fixing
- 6 uprights for size 2 m
- Gap between 2 uprights: 864 mm
- Gap between lower shelf and worktop: 525 mm
- Internal drawer dimensions:
- L 1000 and L 2000: 830x550x110 mm
- L 1500: 1280x550x110 mm
- Supplied disassembled

CODE	DIMENSIONS LxDxH	Weight	N° drawers
U05060144	1046x700x910 mm	55 kg	1
U05060145	1500x700x910 mm	75 kg	1
U05060146	2000x700x910 mm	100 kg	2

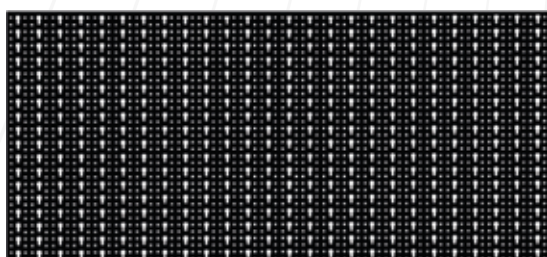

## 501 P

RAL 9005

### Perforated panels

- Hole diameter: 5 mm
- Steel sheet, thickness 1,2 mm

CODE	SIZE	DIMENSIONS LxDxH	Weight
U05010103Q	C	1000x800x40mm	9,5 kg
U05010104Q	A	1500x800x40 mm	13,5 kg
U05010105Q	B	2000x800x40 mm	17,5 kg





## 506 TA

RAL 9005

STEEL

### Workbench with sheet steel top

- Galvanized sheet steel top (thickness 3 mm) with sides 37 mm
- Metal sheet-steel doors uprights and lower shelf, thickness 1,2 mm
- Side holes for fixing multiple benches side by side.
- Arranged for ground fixing
- 6 uprights for size 2 m
- Gap between 2 uprights: 864 mm
- Gap between lower shelf and worktop: 660 mm
- Supplied disassembled

CODE	DIMENSIONS LxDxH	Weight
U05060054	1046x700x910 mm	50 kg
U05060055	1500x700x910 mm	60 kg
U05060056	2000x700x910 mm	80 kg



## 506 TL

RAL 9005

WOOD

### Workbench with wooden top

- Multilayer wooden top, thickness 30 mm
- Metal sheet-steel doors uprights and lower shelf, thickness 1,2 mm
- Side holes for fixing multiple benches side by side.
- Arranged for ground fixing
- 6 uprights for size 2 m
- Gap between 2 uprights: 864 mm
- Gap between lower shelf and worktop: 660 mm
- Supplied disassembled

CODE	DIMENSIONS LxDxH	Weight
U05060044	1046x700x910 mm	40 kg
U05060045	1500x700x910 mm	50 kg
U05060046	2000x700x910 mm	70 kg



## 506 TC

RAL 9005

### Drawers for workbenches

- Compatibility with 506 TA and 506 TL models
- Slides with load resistance up to 60 kg

CODE	SIZE	INT. DIMENSIONS LxDxH	Weight
U05060154Q	1	830x550x110 mm	15 kg
U05060155Q	2	1280x550x110 mm	25 kg



## 516 START ROLLER CABINET MORE RESISTANT AND RELIABLE.

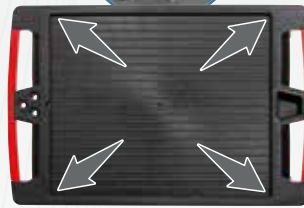

New worktop 460 x 560 mm  
with 15 mm sides



High resistance 35 mm slides  
with a load capacity up to 40 kg



New drawer handles in high resistant  
ABS with selective opening



### Save your time

All USAG roller cabinets are immediately ready for use, because they are supplied with the wheels already mounted on the structure.



800 kg

5  
DRAWERS

3  
MODULES



**516 ST5V**  
U05160105

RAL 3020

#### START roller cabinet (empty)

- Inside dimensions:
  - 2 drawers 570x420x60 mm.
  - 2 drawers 570x420x130 mm.
  - 1 drawer 570x420x270 mm.



800 kg

6  
DRAWERS

3  
MODULES

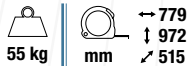

**516 ST6V**  
U05160106

RAL 3020

#### START roller cabinet (empty)

**516 ST6NV**  
U05160116

RAL 9005

#### START roller cabinet (empty)

- Inside dimensions:
  - 3 drawers 570x420x60 mm.
  - 2 drawers 570x420x130 mm.
  - 1 drawer 570x420x200 mm.



800 kg

7  
DRAWERS

3  
MODULES



**516 ST7V**  
U05160107

RAL 3020

#### START roller cabinet (empty)

**516 ST7NV**  
U05160117

RAL 9005

#### START roller cabinet (empty)

- Inside dimensions:
  - 5 drawers 570x420x60 mm.
  - 1 drawer 570x420x130 mm.
  - 1 drawer 570x420x200 mm.



**516 ST8V**  
U05160108

RAL 3020

**START roller cabinet (empty)**

- Inside dimensions:
  - 6 drawers 570x420x60 mm.
  - 2 drawers 570x420x130 mm.



**516 STXL6V**  
U05160146

RAL 3020

**START roller cabinet (empty)**

- Inside dimensions:
  - 3 drawers 760x420x60 mm.
  - 2 drawers 760x420x130 mm.
  - 1 drawer 760x420x200 mm.



**516 STXL6NV**  
U05160156

RAL 9005

**START roller cabinet (empty)**

- Inside dimensions:
  - 3 drawers 760x420x60 mm.
  - 2 drawers 760x420x130 mm.
  - 1 drawer 760x420x200 mm.



**504 SR**  
U05040004

RAL 3020

**Multi-purpose roller cabinet**

- 3 shelves 770x448 mm
- Shelves covered by 2 mm ABS mats
- 37 mm anti-fall edges on all 3 shelves
- Steel handle Ø 25 mm
- Possibility to hang 516 accessories in the lateral sides
- Two fixed and two swivelling (Ø 100 mm), one of which has a brake
- Supplied disassembled
- Maximum loading capacity: 200 Kg

**504 SN**  
U05040014

RAL 9005

**Multi-purpose roller cabinet**



**504 SNA**  
U05040015

RAL 9005

**Multi-purpose roller cabinet**

- 3 shelves 770x448 mm
- Shelves covered by 2 mm ABS mats
- 37 mm anti-fall edges on all 3 shelves
- Steel handle Ø 25 mm
- Possibility to hang 516 accessories in the lateral sides
- Two fixed and two swivelling (Ø 100 mm), one of which has a brake
- Drawer with slides (load capacity up to 20 kg)
- Double key supplied
- Supplied disassembled
- Maximum loading capacity: 200 Kg



**516 STC4V**  
U05160104

RAL 3020

**START drawer chest (empty)**

- Inside dimensions:
  - 3 drawers: 570x420x60 mm.
  - 1 drawers: 570x420x130 mm.

# Roller cabinets

**CAN'T FIND**  
Go now to



**6**  
DRAWERS

**3**  
MODULES



**6**  
DRAWERS

**3**  
MODULES

**157**  
PIECES



**516 ST6PM**  
U05160630

RAL 3020

**516 ST6NPM**  
U05161630

RAL 9005

**START roller cabinet with MAINTENANCE assortment 495 PM - 4 drawers**

**142**  
PIECES



**516 ST6PA**  
U05160629

RAL 3020

**516 ST6NPA**  
U05161629

RAL 9005

**START roller cabinet with AUTOMOTIVE assortment 495 PA - 2 drawers**

## MAINTENANCE ASSORTMENT



519/613AEA 519/613CEA 519 SK692V



519/285A1 519/150AX 519 SK692V



519/324H 519/324TX 519 SK692V + 692 J32



519 SK692V 519/990A1 519/382F

DESCRIPTION	ITEM	PCS.
Hexagonal sockets, ratchet (237 A 1/4"), accessories 1/4" and bits	519/613AEA	42
Hexagonal sockets, ratchet (237 A 1/2") and accessories 1/2"	519/613CEA	22
Combination wrenches (6-7-8-9-10-11-12-13-14-15-16-17-18-19-22-24 mm) and angled keys (1,5-2-2,5-3-4-5-6-8-10 mm)	519/285A1	25
Universal pliers, adjustable pliers, cutting nippers, extra-long nose pliers, lock-grip pliers	519/150AX	5
Screwdrivers for slot-head and PHILLIPS® screws	519/324H	10
Screwdrivers for TORX® screws	519/324TX	9
Flat square file, half-round file, round file, triangular file (second cut)	519/990A1	4
Hammers, chisels and pin punches	519/382F	8
Assortment with bits and reversible ratchet	692 J32	32

## AUTOMOTIVE ASSORTMENT



519/613AEA 519/613CEA 519 SK692V + 692 J32



519/324H 519/285A1 519/150AX



**T-WRENCHES WITH JOINT**  
7-8-10-12-13-17 mm

DESCRIPTION	ITEM	PCS.
Hexagonal sockets, ratchet (237 A 1/4"), accessories 1/4" and bits	519/613AEA	42
Hexagonal sockets, ratchet (237 A 1/2") and accessories 1/2"	519/613CEA	22
Screwdrivers for slot-head and PHILLIPS® screws	519/324H	10
Combination wrenches (6-7-8-9-10-11-12-13-14-15-16-17-18-19-22-24 mm) and angled keys (1,5-2-2,5-3-4-5-6-8-10 mm)	519/285A1	25
Universal pliers, adjustable pliers, cutting nippers, extra-long nose pliers, lock-grip pliers	519/150AX	5
T-handle wrenches with jointed hexagonal socket (7-8-10-12-13-17 mm)	276 CE	6
Assortment with bits and reversible ratchet	692 J32	32

**Do you want only the assortment? Go to page 29**

## YOUR IDEAL ASSORTMENT? Kitplanner-gb.usag.it and create it!



**6**  
DRAWERS

**3**  
MODULES



**6**  
DRAWERS

**3**  
MODULES

**156**  
PIECES

**516 ST6MM**  
U05160628

RAL  
3020



**516 ST6NMM**  
U05161628

RAL  
9005

**START roller cabinet with assortment for  
MAINTENANCE 495 MB - 4 drawers**

**155**  
PIECES

**516 ST6MA**  
U05160627

RAL  
3020



**516 ST6NMA**  
U05161627

RAL  
9005

**START roller cabinet with AUTOMOTIVE  
assortment 495 MAA - 3 drawers**

### MAINTENANCE ASSORTMENT



519 M 613AEA 519 M 613CEA 519 M 285A1



519 M 127C 519 M 150AX 519 MSK6



519 M 324H 519 M 324STX 519 MSK6+  
692 J32



519 M 990A5MD 519 M 382 519 MSK6

### AUTOMOTIVE ASSORTMENT

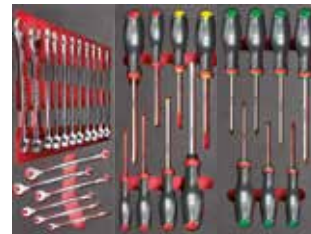

519 M 285A1 519 M 324H 519 M 324STX



519 M 613AEA 519 M 612CLA

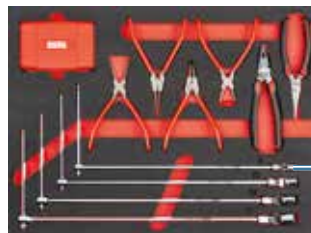

519 M 276C



**T-WRENCHES WITH JOINT**

8-10-13-17 mm

DESCRIPTION	ITEM	PCS.
Hexagonal sockets, ratchet (237 A 1/4"), accessories 1/4" and bits	519 M 613AEA	46
Hexagonal sockets, ratchet (237 A 1/2") and accessories 1/2"	519 M 613CEA	23
Combination wrenches (6-7-8-9-10-11-12-13-14-15-16-17-18-19-21-22-24 mm)	519 M 285A1	17
Pliers for circlips internal and external 15÷25 and 19÷60	519 M 127C	6
Universal pliers, adjustable pliers, cutting nippers, extra-long nose pliers, lock-grip pliers	519 M 150AX	5
Screwdrivers for slot-head and PHILLIPS® screws	519 M 324H	7
Screwdrivers for TORX® Tamper Resistant screws	519 M 324STX	8
Flat square file, half-round file, round file, square file, triangular file (second cut)	519 M 990A5MD	5
Hammer for mechanics with graphite handle, mallet, pin punches, chisel and centre punch	519 M 382F	7
Assortment with bits and reversible ratchet	692 J32	32

DESCRIPTION	ITEM	PCS.
Hexagonal sockets, ratchet (237 A 1/4"), accessories 1/4" and bits	519 M 613AEA	46
Bihexagonal sockets, ratchet (237 A 1/2") and accessories 1/2"	519 M 612CLA	35
Combination wrenches (6-7-8-9-10-11-12-13-14-15-16-17-18-19-21-22-24 mm)	519 M 285A1	17
Screwdrivers for slot-head and PHILLIPS® screws	519 M 324H	7
Screwdrivers for TORX® Tamper Resistant screws	519 M 324STX	8
Pliers for circlips, combination pliers, long nose pliers, T-handle wrenches with hex sockets (8-10-13-17 mm), bits set with ratchet	519 M 276C	42

**Do you want only the assortment? Go to page 28**

# Roller cabinets

**CAN'T FIND**  
Go now to



**6**  
DRAWERS

**4**  
MODULES



**6**  
DRAWERS

**4**  
MODULES

**301**  
PIECES

**516 STXL6MM**  
U05160632

RAL  
3020

**START XL roller cabinet with assortment for MAINTENANCE 495 MC - 4 drawers**



**301**  
PIECES

**516 STXL6NMM**  
U05161632

RAL  
9005

**START XL roller cabinet with assortment for MAINTENANCE 495 MC - 4 drawers**



## MAINTENANCE ASSORTMENT



519 M 612CLA

519 M 613BEA

519 M 613AEA

519 M 285KA

519 M 285A1

519 M 285A2

519 M 294B

519 M 324H

519 M 324STX

519 M 280HG

519 M 280N1

519 M 127C

519 M 150AX

519 M 382F

519 M 990A5MD

DESCRIPTION	ITEM	PCS.
Hexagonal sockets, ratchet (237 A 1/4"), accessories 1/4" and bits	519 M 613AEA	46
Hexagonal sockets, ratchet (237 A 3/8") and accessories 3/8"	519 M 613BEA	20
Bi-hexagonal sockets, ratchet (237 A 1/2") and accessories 1/2"	519 M 612CLA	35
Reversible ratchet combination wrenches 8-9-10-11-12-13-14-15-16-17-18-19 mm	519 M 285 KA	12
Combination wrenches (6-7-8-9-10-11-12-13-14-15-16-17-18-19-21-22-24 mm)	519 M 285A1	17
Combination wrenches 27-29-30-32-34 mm	519 M 285A2	5
Adjustable wrenches, lock-grip pliers and scissor	519 M 294B	4
Screwdrivers for slot-head and PHILLIPS® screws	519 M 324H	7

DESCRIPTION	ITEM	PCS.
Screwdrivers for TORX® Tamper Resistant screws	519 M 324STX	8
Hexagon keys with handgrip (3-4-5-6-7-8-10 mm)	519 M 280HG	7
Set of keys for TORX® screws and assortment of bits with special shapes	519 M 280N1	117
Pliers for circlips internal and external 15÷25 and 19÷60	519 M 127C	6
Universal pliers, adjustable pliers, cutting nippers, extra-long nose pliers, lock-grip pliers	519 M 150AX	5
Flat square file, half-round file, round file, square file, triangular file (second cut)	519 M 990A5MD	5
Hammer for mechanics with graphite handle, mallet, pin punches, chisel and centre punch	519 M 382F	7

**Do you want only the assortment? Go to page 28**

**YOUR IDEAL ASSORTMENT?**  
Kitplanner-gb.usag.it and create it!



**6**  
DRAWERS

**3**  
MODULES



**6**  
DRAWERS

**3**  
MODULES



**264**  
PIECES

**516 ST6MMEX**  
U05160634

RAL  
3020

**START roller cabinet with assortment for  
MAINTENANCE 495 MMEX - 4 drawers**



**264**  
PIECES

**516 ST6NMMEX**  
U05161634

RAL  
9005

**START roller cabinet with assortment for  
MAINTENANCE 495 MMEX - 4 drawers**



## MAINTENANCE ASSORTMENT



519 M 601



519 M 324H

519 M 324STX

519 M 280N1



519 M 127N

519 M 150AX

519 M 382F

DESCRIPTION	ITEM	PCS.	DESCRIPTION	ITEM	PCS.
Universal pliers, adjustable pliers, cutting nippers, extra-long nose pliers, lock-grip pliers	519 M 150AX	5	Hammer for mechanics with graphite handle, mallet, pin punches, chisel and centre punch	519 M 382F	7
Pliers for circlips internal and external 19÷60	519 M 127N	4	Adjustable wrenches, lock-grip pliers and scissor, Hexagonal sockets 1/4" 4÷14 mm - 1/2" 10÷32 mm, Long hexagonal sockets 1/4" 6÷14 mm - 1/2" 13÷22 mm, Socket bits 1/4" for PH, PZ, slot-head, hexagonal, Torx screw, Ratchet and accessories 1/4" - 1/2", Spark plug sockets 1/2" 16-21 mm, Torx sockets 1/4" - 1/2" E6÷ E24, Bits 5/16" for PH, PZ, slot-head, hexagonal, Torx, XZN screw	519 M 601	116
Set of keys for TORX® screws and assortment of bits with special shapes	519 M 280N1	117			
Screwdrivers for slot-head and PHILLIPS® screws	519 M 324H	7			
Screwdrivers for TORX® Tamper Resistant screws	519 M 324STX	8			

**Do you want only the assortment? Go to page 28**



## 519 RACING ROLLER CABINET YOUR PREMIUM AND PROFESSIONAL WORKSHOP.



**TWO WHEELS  
WITH BRAKE**

A new wider worktop  
With double handle

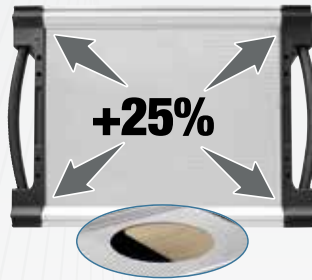

Double layer  
Above: 2 mm aluminium plate.  
Below: 15 mm wooden piece.



Rubber bumpers on  
structure and drawers



New aluminium ergonomic handles  
with selective opening



### Save your time

All USAG roller cabinets are immediately ready for use, because they are supplied with the wheels already mounted on the structure



900 kg

**8  
DRAWERS**  
**3  
MODULES**

79 kg | mm | → 814  
↓ 1005  
↙ 575



900 kg

**7  
DRAWERS**  
**3  
MODULES**

77 kg | mm | → 814  
↓ 1005  
↙ 575



900 kg

**6  
DRAWERS** | **3  
MODULES**

75 kg | mm | → 814  
↓ 1005  
↙ 575

### 519 RS6/3V

U05190506

RAL 3020

**RACING roller cabinet (empty)**

### 519 RS8/3V

U05190508

RAL 3020

**RACING roller cabinet (empty)**

- Inside dimensions:
  - 6 drawers 570x420x60 mm.
  - 2 drawers 570x420x130 mm.

### 519 RS7/3V

U05190507

RAL 3020

**RACING roller cabinet (empty)**

- Inside dimensions:
  - 5 drawers 570x420x60 mm.
  - 1 drawer 570x420x130 mm.
  - 1 drawer 570x420x200 mm.

### 519 RS6/3NV

U05190516

RAL 9005

**RACING roller cabinet (empty)**

- Inside dimensions:
  - 4 drawers 570x420x60 mm.
  - 1 drawer 570x420x130 mm.
  - 1 drawer 570x420x270 mm.





1000 kg

**6**  
DRAWERS

**4**  
MODULES

89 kg | 1004 mm | 1005 mm | 575 mm

**519 RS6/4V**

U05190546

RAL 3020

**RACING roller cabinet (empty)**

**519 RS6/4NV**

U05190566

RAL 9005

**RACING roller cabinet (empty)**

- Inside dimensions:
  - 4 drawers 760x420x60 mm.
  - 1 drawer 760x420x130 mm.
  - 1 drawer 760x420x270 mm.



1100 kg

**7**  
DRAWERS

**5**  
MODULES

106 kg | 1194 mm | 1035 mm | 575 mm

**519 RS7/5V**

U05190556

RAL 3020

**RACING roller cabinet (empty)**

- Inside dimensions:
  - 5 drawers 950x420x60 mm.
  - 1 drawer 950x420x130 mm.
  - 1 drawer 950x420x200 mm.



1100 kg

**7**  
DRAWERS

**3**  
MODULES

106 kg | 1194 mm | 1035 mm | 575 mm

**519 RB07/3V**

U05190097

RAL 3020

**RACING roller cabinet with side door (empty)**

- Inside dimensions:
  - 5 drawers 570x420x60 mm.
  - 1 drawer 570x420x130 mm.
  - 1 drawer 570x420x200 mm.
- Side compartment: 380x400x720 mm.



1100 kg



**4**  
DRAWERS

**3**  
MODULES

45 kg | 814 mm | 500 mm | 575 mm

**519 RSC4/3V**

U05190534

RAL 3020

**RACING drawer chest (empty)**

- Inside dimensions:
  - 3 drawers: 570x420x60 mm.
  - 1 drawer: 570x420x130 mm.



**4**  
DRAWERS

**4**  
MODULES

51 kg | 1004 mm | 500 mm | 575 mm

**519 RSC4/4V**

U05190544

RAL 3020

**RACING drawer chest (empty)**

- Inside dimensions:
  - 3 drawers: 760x420x60 mm.
  - 1 drawer: 760x420x130 mm.

**6**  
DRAWERS

**3**  
MODULES

128 kg | 1.212 mm | 1000 mm | 670 mm

**519 RBU6/3V**

U05190098

RAL 3020

RAL 9005

**RACING mobile workbench (empty)**

- Inside dimensions:
  - 3 drawers 570x420x60 mm.
  - 2 drawers 570x420x130 mm.
  - 1 drawer 570x420x200 mm.
- Side compartment: 380x524x704 mm.



**4**  
DRAWERS

**5**  
MODULES

60 kg | 1194 mm | 500 mm | 575 mm

**519 RSC4/5V**

U05190554

RAL 3020

**RACING drawer chest (empty)**

- Inside dimensions:
  - 3 drawers: 950x420x60 mm.
  - 1 drawer: 950x420x130 mm.

# Roller cabinets

**CAN'T FIND**  
Go now to



**6**  
DRAWERS

**3**  
MODULES



**6**  
DRAWERS

**3**  
MODULES

**156**  
PIECES

**519 RS6/3MM**  
U05190628

RAL 3020



**519 RS6/3NMM**  
U05191628

RAL 9005

**RACING roller cabinet with assortment for MAINTENANCE 495 MB - 4 drawers**

**155**  
PIECES

**519 RS6/3MA**  
U05190627

RAL 3020



**519 RS6/3NMA**  
U05191627

RAL 9005

**RACING roller cabinet with AUTOMOTIVE assortment 495 MAA - 3 drawers**

## MAINTENANCE ASSORTMENT



519 M 613AEA 519 M 613CEA 519 M 285A1



519 M 127C 519 M 150AX 519 MSK6



519 M 324H 519 M 324STX 519 MSK6+ 692 J32



519 M 990A5MD 519 M 382 519 MSK6

### DESCRIPTION

DESCRIPTION	ITEM	PCS.
Hexagonal sockets, ratchet (237 A 1/4"), accessories 1/4" and bits	519 M 613AEA	46
Hexagonal sockets, ratchet (237 A 1/2") and accessories 1/2"	519 M 613CEA	23
Combination wrenches (6-7-8-9-10-11-12-13-14-15-16-17-18-19-21-22-24 mm)	519 M 285A1	17
Pliers for circlips internal and external 15÷25 and 19÷60	519 M 127C	6
Universal pliers, adjustable pliers, cutting nippers, extra-long nose pliers, lock-grip pliers	519 M 150AX	5
Screwdrivers for slot-head and PHILLIPS® screws	519 M 324H	7
Screwdrivers for TORX® Tamper Resistant screws (T10-T15-T20-T25-T30-T40)	519 M 324STX	8
Flat square file, half-round file, round file, square file, triangular file (bastard cut)	519 M 990A5MD	5
Hammer for mechanics with graphite handle, mallet, pin punches, chisel and centre punch	519 M 382F	7
Assortment with bits and reversible ratchet	692 J32	32

## AUTOMOTIVE ASSORTMENT



519 M 285A1 519 M 324H 519 M 324STX



519 M 613AEA 519 M 612CLA



519 M 276C



**T-WRENCHES WITH JOINT**  
8-10-13-17 mm

### DESCRIPTION

DESCRIPTION	ITEM	PCS.
Hexagonal sockets, ratchet (237 A 1/4"), accessories 1/4" and bits	519 M 613AEA	46
Bihexagonal sockets, ratchet (237 A 1/2") and accessories 1/2"	519 M 612CLA	35
Combination wrenches (6-7-8-9-10-11-12-13-14-15-16-17-18-19-21-22-24 mm)	519 M 285A1	17
Screwdrivers for slot-head and PHILLIPS® screws	519 M 324H	7
Screwdrivers for TORX® Tamper Resistant screws	519 M 324STX	8
Pliers for circlips, combination pliers, long nose pliers, T-handle wrenches with hex sockets (8-10-13-17 mm), bits set with ratchet	519 M 276C	42

**Do you want only the assortment? Go to page 28**

## YOUR IDEAL ASSORTMENT?

Kitplanner-gb.usag.it and create it!



**6**  
DRAWERS

**4**  
MODULES



**8**  
DRAWERS

**3**  
MODULES

**301**  
PIECES

**519 RS6/4MM**  
U05190632

RAL  
3020



**519 RS6/4NMM**  
U05191632

RAL  
9005

**RACING roller cabinet with assortment for MAINTENANCE 495 MC - 4 drawers**

**301**  
PIECES

**519 RS8/3MM**  
U05192632

RAL  
3020



**RACING roller cabinet with assortment for MAINTENANCE 495 MC - 4 drawers**

## MAINTENANCE ASSORTMENT



DESCRIPTION	ITEM	PCS.
Hexagonal sockets, ratchet (237 A 1/4"), accessories 1/4" and bits	519 M 613AEA	46
Hexagonal sockets, ratchet (237 A 3/8") and accessories 3/8"	519 M 613BEA	20
Bihexagonal sockets, ratchet (237 A 1/2") and accessories 1/2"	519 M 612CLA	35
Reversible ratchet combination wrenches 8-9-10-11-12-13-14-15-16-17-18-19 mm	519 M 285 KA	12
Combination wrenches (6-7-8-9-10-11-12-13-14-15-16-17-18-19-21-22-24 mm)	519 M 285A1	17
Combination wrenches 27-29-30-32-34 mm	519 M 285A2	5
Adjustable wrenches, lock-grip pliers and scissor	519 M 294B	4
Screwdrivers for slot-head and PHILLIPS® screws	519 M 324H	7

DESCRIPTION	ITEM	PCS.
Screwdrivers for TORX® Tamper Resistant screws (T10-T15-T20-T25-T30-T40)	519 M 324STX	8
Hexagon keys with handgrip (3-4-5-6-7-8-10 mm)	519 M 280HG	7
Set of keys for TORX® screws and assortment of bits with special shapes	519 M 280N1	117
Pliers for circlips internal and external 15÷25 and 19÷60	519 M 127C	6
Universal pliers, adjustable pliers, cutting nippers, extra-long nose pliers, lock-grip pliers	519 M 150AX	5
Flat square file, half-round file, round file, square file, triangular file (second cut)	519 M 990A5MD	5
Hammer for mechanics with graphite handle, mallet, pin punches, chisel and centre punch	519 M 382F	7

**Do you want only the assortment? Go to page 28**

## BI-COLOUR FOAM MODULES



519 M 613AEA 519 M 613CEA 519 M 285A1



519 M 127C 519 M 150AX 519 MSK6



519 M 324H 519 M 324STX 519 MSK6+692 J32



519 M 990A5MD 519 M 382 519 MSK6



519 M 285A1 519 M 324H 519 M 324STX



519 M 613AEA 519 M 612CLA



519 M 276C



### T-HANDLE WRENCHES 8-10-13-17 mm

**495 MB**  
U04950628

**156**  
PIECES



#### Assortment for MAINTENANCE - 4 drawers

DESCRIPTION	ITEM	PCS.
Hexagonal sockets, ratchet (237 A 1/4"), accessories 1/4" and bits	519 M 613AEA	46
Hexagonal sockets, ratchet (237 A 1/2") and accessories 1/2"	519 M 613CEA	23
Combination wrenches (6-7-8-9-10-11-12-13-14-15-16-17-18-19-21-22-24 mm)	519 M 285A1	17
Pliers for circlips internal and external 15÷25 and 19÷60	519 M 127C	6
Universal pliers, adjustable pliers, cutting nippers, extra-long nose pliers, lock-grip pliers	519 M 150AX	5
Screwdrivers for slot-head and PHILLIPS® screws	519 M 324H	7
Screwdrivers for TORX® Tamper Resistant screws	519 M 324STX	8
Flat square file, half-round file, round file, square file, triangular file (second cut)	519 M 990A5MD	5
Hammer for mechanics with graphite handle, mallet, pin punches, chisel and centre punch	519 M 382F	7
Assortment with bits and reversible ratchet	692 J32	32

**495 MAA**  
U04950627

**155**  
PIECES



#### Assortment for car repair - 3 drawers

DESCRIPTION	ITEM	PCS.
Hexagonal sockets, ratchet (237 A 1/4"), accessories 1/4" and bits	519 M 613AEA	46
Biexagonal sockets, ratchet (237 A 1/2") and accessories 1/2"	519 M 612CLA	35
Combination wrenches (6-7-8-9-10-11-12-13-14-15-16-17-18-19-21-22-24 mm)	519 M 285A1	17
Screwdrivers for slot-head and PHILLIPS® screws	519 M 324H	7
Screwdrivers for TORX® Tamper Resistant screws	519 M 324STX	8
Pliers for circlips, combination plier, long nose pliers, T-handle wrenches with hex sockets (8-10-13-17 mm), bits set with ratchet	519 M 276C	42



519 M 612CLA 519 M 613BEA 519 M 613AEA



519 M 285KA 519 M 285A1 519 M 285A2 519 M 294B

**301**  
PIECES



**495 MC**  
U04950632

#### Assortment for MAINTENANCE - 4 drawers



519 M 324H 519 M 324STX 519 M 280HG 519 M 280N1



519 M 127C 519 M 150AX 519 M 382F 519 M 990A5MD

## PLASTIC TRAYS



519/613AEA 519/613CEA 519 SK692V



519/285A1 519/150AX 519 SK692V



519/324H 519/324TX 519 SK692V + 692 J32



519 SK692V 519/990A1 519/382F



519/613AEA 519/613CEA 519 SK692V + 692 J32



519/324H 519/285A1 519/150AX

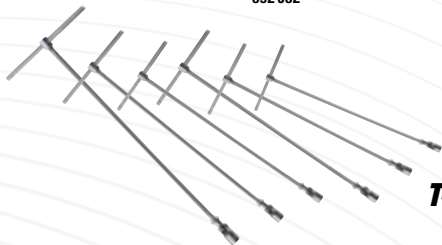

**T-HANDLE WRENCHES**  
7-8-10-12-13-17 mm

**495 PM**  
U04950630

**157**  
PIECES



### Assortment for MAINTENANCE - 4 drawers

DESCRIPTION	ITEM	PCS.
Hexagonal sockets, ratchet (237 A 1/4"), accessories 1/4" and bits	519/613AEA	42
Hexagonal sockets, ratchet (237 A 1/2") and accessories 1/2"	519/613CEA	22
Combination wrenches (6-7-8-9-10-11-12-13-14-15-16-17-18-19-22-24 mm) and angled keys (1,5-2-2,5-3-4-5-6-8-10 mm)	519/285A1	25
Universal pliers, adjustable pliers, cutting nippers, extra-long nose pliers, lock-grip pliers	519/150AX	5
Screwdrivers for slot-head and PHILLIPS® screws	519/324H	10
Screwdrivers for TORX® screws	519/324TX	9
Flat square file, half-round file, round file, triangular file (second cut)	519/990A1	4
Hammers, chisels and pin punches	519/382F	8
Assortment with bits and reversible ratchet	692 J32	32

**495 PA**  
U04950629

**142**  
PIECES



### Assortment for car repair - 2 drawers

DESCRIPTION	ITEM	PCS.
Hexagonal sockets, ratchet (237 A 1/4"), accessories 1/4" and bits	519/613AEA	42
Hexagonal sockets, ratchet (237 A 1/2") and accessories 1/2"	519/613CEA	22
Screwdrivers for slot-head and PHILLIPS® screws	519/324H	10
Combination wrenches (6-7-8-9-10-11-12-13-14-15-16-17-18-19-22-24 mm) and angled keys (1,5-2-2,5-3-4-5-6-8-10 mm)	519/285A1	25
Universal pliers, adjustable pliers, cutting nippers, extra-long nose pliers, lock-grip pliers	519/150AX	5
T-handle wrenches with jointed hexagonal socket (7-8-10-12-13-17 mm)	276 CE	6
Assortment with Ribe bits with hole - XZN - TORX® Tamper Resistant	692 J32	32

DESCRIPTION	ITEM	PCS.
Hexagonal sockets, ratchet (237 A 1/4"), accessories 1/4" and bits	519 M 613AEA	46
Hexagonal sockets, ratchet (237 A 3/8") and accessories 3/8"	519 M 613BEA	20
Biexagonal sockets, ratchet (237 A 1/2") and accessories 1/2"	519 M 612CLA	35
Reversible ratchet combination wrenches 8-9-10-11-12-13-14-15-16-17-18-19 mm	519 M 285 KA	12
Combination wrenches (6-7-8-9-10-11-12-13-14-15-16-17-18-19-21-22-24 mm)	519 M 285A1	17
Combination wrenches 27-29-30-32-34 mm	519 M 285A2	5
Adjustable wrenches, lock-grip pliers and scissor	519 M 294B	4
Screwdrivers for slot-head and PHILLIPS® screws	519 M 324H	7
Screwdrivers for TORX® Tamper Resistant screws	519 M 324STX	8
Hexagon keys with handgrip (3-4-5-6-7-8-10 mm)	519 M 280HG	7
Set of keys for TORX® screws and assortment of bits with special shapes	519 M 280N1	117
Pliers for circlips internal and external 15÷25 and 19÷60	519 M 127C	6
Universal pliers, adjustable pliers, cutting nippers, extra-long nose pliers, lock-grip pliers	519 M 150AX	5
Flat square file, half-round file, round file, square file, triangular file (second cut)	519 M 990A5MD	5
Hammer for mechanics with graphite handle, mallet, pin punches, chisel and centre punch	519 M 382F	7



**CAN'T FIND YOUR IDEAL ASSORTMENT?**  
Go now to [kitplanner-gb.usag.it](http://kitplanner-gb.usag.it) and create it!

# Plastic trays



**519/127N**  
**U05190716** **4** PIECES  
127 N 19÷60 · 127 PN 19÷60 ·  
128 N 19÷60 · 128 PN 19÷60.



**519/150AX**  
**U05190850** **5** PIECES  
133 AX 160 · 134 250 · 150 AX 180 ·  
180 C 250 · 188 AX 160.



**519/280HG**  
**U05191860** **7** PIECES  
280 HG 3-4-5-6-7-8-10.



**519/280HGTS**  
**U05191861** **7** PIECES  
280 HGTS 3-4-5-6-7-8-10.



**519/285A1**  
**U05190785** **25** PIECES  
285 6-7-8-9-10-11-12-13-14-15-16-17-  
18-19-22-24 280 S9 1,5÷10.



**519/285B2**  
**U05190823** **4** PIECES  
285 27-29-30-32.



**519/285KA1**  
**U05190788** **12** PIECES  
285 KA 8-9-10-11-12-13-14-15-  
16-17-18-19.



**519/294**  
**U05190732** **9** PIECES  
204 250 · 294 A 250 · 367 2x110-3x130-  
4x145-5x165-6x180-8x200 · 981 A3.



**519/322H**  
**U05190772** **10** PIECES  
322 0,5x3x75-0,8x4x100-1x5,5x125-  
1,2x6,5x150-1,6x8x175 · 322 PH 0x75-1x100-  
2x125 · 322 N 0,8x4x30 · 322 NPH 2x30.



**519/322STX**  
**U05190831** **6** PIECES  
322 STX T10-T15-T20-T25-T30-T40.



**519/324H**  
**U05190763** **10** PIECES  
324 0,5x3x75-0,8x4x100-1x5,5x125-  
1,2x6,5x150-1,2x8x200 · 324 PH 0x75-1x75-  
2x100 · 324 N 0,8x4x35 · 324 NPH 2x35.



**519/324TX**  
**U05190764** **9** PIECES  
324 TX T6x50-T7x50-T8x50-T9x75 · 324 STX  
T10x75-T15x75-T20x100-T25x100-T30x125.



**519/366**  
**U05190740** **7** PIECES  
351 200 · 362 125-150 · 364 125 ·  
366 3x125 · 4x150 · 368 4x125.



**519/382F**  
**U05190742** **8** PIECES  
362 150 · 367 2x100-3x130-4x145-  
5x165 · 368 4x125 · 376 35 · 382F 500.



**519/613AEA** **42** PIECES  
**U05190784** 237 A  
235 1/4" EN 4-4,5-5-5,5-6-7-8-9-10-11-12-13-  
14 · 236 1/4" 50-150 · 237 A 1/4" · 240 1/4" ·  
241 1/4" · 243 1/4" · 692 S11 · 692 STX/S11 ·  
684 1/4"-1/4".



**519/613BEA** **21** PIECES  
**U05190747** 237 A  
235 3/8" E 6-7-8-9-10-11-12-13-14-15-  
16-17-18-19-21-22 · 236 3/8" 125-250 ·  
237 A 3/8" · 240 3/8" N · 241 3/8".



**519/613CEA** **22** PIECES  
**U05190750** 237 A  
235 1/2" EN 10-11-12-13-14-15-16-  
17-18-19-20-21-22-24-27-30-32 · 236  
1/2" 125-250 · 237 A 1/2" · 240 1/2" N  
· 241 1/2".



**519/990A1** **4** PIECES  
**U05190825**  
990 M PA/200 · 990 M PB/200  
990 M PC/200 · 990 M PE/200.

**Create your ideal assortment**

*This is just a selection of the available assortments at Superoffer Conditions: on [kitplanner-gb.usag.it](http://kitplanner-gb.usag.it) you can find 200 modules and 120 assortments to choose!*



**8** PIECES **XL**  
**519/280T**  
**U05190727**  
280 T 2-2,5-3-4-5-6-8-10.



**8** PIECES **XXL**  
**519/276**  
**U05190725**  
276 CE 7-8-10-11-13-14-17-19.

# Bi-colour foam modules

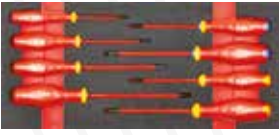

**519 M 091A**  
**U05191016** **8** PIECES  
091 0,5x3x75-0,8x4x100-1x5,5x125  
1,2x6,5x150 · 091 PH 1x100-2x125  
· 091 PZ 1x100-2x125.



**519 M 127N**  
**U05190937** **4** PIECES  
127 N 19÷60 · 127 PN 19÷60 ·  
128 N 19÷60 · 128 PN 19÷60.



**519 M 150AX**  
**U05190965** **5** PIECES  
133 AX 160 · 134 250 · 150 AX 180 ·  
180 C 250 · 188 AX 160.



**519 M 280HG**  
**U05191945** **7** PIECES  
280 HG 3-4-5-6-7-8-10.



**519 M 280HGTS**  
**U05191946** **7** PIECES  
280 HGTS 3-4-5-6-7-8-10.



**519 M 280N1**  
**U05191013** **117** PIECES  
280 S9 1,5-2-2,5-3-4-5-6-8-10 · 280 TX/  
S8C T10-T15-T20-T25-T27-T30-T40-T45  
· 692 J100.

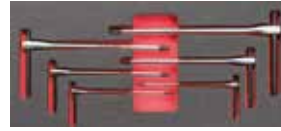

**519 M 280TK**  
**U05190935** **6** PIECES  
280 TK 2,5-3-4-5-6-8.



**519 M 285A1**  
**U05190921** **17** PIECES  
285 6-7-8-9-10-11-12-13-14-15-16-  
17-18-19-21-22-24.



**519 M 285A2**  
**U05190943** **5** PIECES  
285 27-29-30-32-34.



**519 M 285KA**  
**U05190944** **12** PIECES  
285 KA 8-9-10-11-12-13-14-15-  
16-17-18-19.

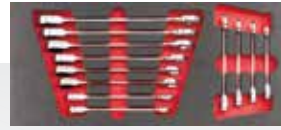

**519 M 285KB**  
**U05191060** **12** PIECES  
285 KB 8-9-10-11-12-13-14-15-  
16-17-18-19.



**519 M 294B**  
**U05191015** **4** PIECES  
135 A 250 · 207 E · 294 AC · 294 AD 250.



**519 M 324H**  
**U05190910** **8** PIECES  
324 0,5x3x75-0,8x4x100-1x5,5x125-  
1,2x6,5x150 · 324 PH 1x100-2x125  
324 D 0,6x3,5x100 324 E 1,6x8x175.



**519 M 324STX**  
**U05190911** **7** PIECES  
324 STX T10x75-T15x75-T20x100-  
T25x100-T27x100-T30x125-T40x150.



**519 M 382F**  
**U05190926** **7** PIECES  
362 175 · 367 2x100-3x130-6x180  
368 3x100 · 376 28 · 382F 500.



**519 M 613AEA** **46** PIECES  
**U05190940** 237 A  
235 1/4" EN 5,5-6-7-8-9-10-11-12-13-14 · 236  
1/4" 50-100 · 237 A 1/4" · 240 1/4" · 241 1/4" ·  
243 1/4" · 280 LTS/S9 · 684 1/4"-1/4" · 660 0,6-  
1-1,6 · 660 E 3-4-5-6-8 · 660 PH 1-2-3 · 660 PZ  
1-2-3 · 660 STX T15-T20-T25-T27-T30-T40.



**519 M 613BEA** **20** PIECES  
**U05190928** 237 A  
235 3/8" E 7-8-9-10-11-12-13-14-15-16-  
17-18-19-21-22 · 236 3/8" 125-250 ·  
237 A 3/8" · 240 3/8" N · 241 3/8".



**519 M 613CEA** **23** PIECES  
**U05190942** 237 A  
235 1/2" EN 8-10-11-12-13-14-15-16-  
17-18-19-21-22-23-24-27-30-32 · 236  
1/2" 125-250 · 237 A 1/2" · 240 1/2" N  
· 241 1/2".



**519 M 990A5MD** **5** PIECES  
**U05191011**  
990 M PA/200 · 990 M PB/200 · 990 M  
PC/200 · 990 M PD/200 · 990 M PE/200.



**519 M 276**  
**U05190936** **7** PIECES **XXL**  
276 CE 7-8-10-11-13-17-19.



**8** PIECES **XL**

**519 M 280T**  
**U05191059**  
280 T 2-2,5-3-4-5-6-8-10.

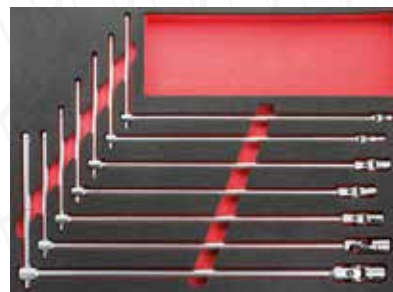

**7** PIECES **XXL**

**519 M 276**  
**U05190936**  
276 CE 7-8-10-11-13-17-19.

# Maintenance suitcases



## 002 JMA U00020011

13 kg | 460 mm | 158 mm | 385 mm

### Case with assortment for maintenance

- Case with Aluminium section shell and metal reinforcements
- Double metal closing hinge with lock (key included)
- Three internal panels equipped with elastics to hold tools
- Base with cut-out bi-colour foam

## 002 JTMA U00020015

14 kg | 485 mm | 200 mm | 377 mm

### Tool trolley with assortment for maintenance



**002 JTMA:  
WHEELS  
INTEGRATED INTO  
THE STRUCTURE**



**IT CONTAINS AX SERIES PLIERS, SCREWDRIVERS 324 AND THE ADJUSTABLE WRENCH 294 AD!**

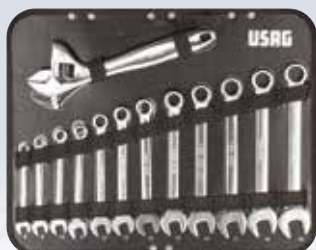

**181  
PIECES**



DESCRIPTION	SIZE	PCS.
Hexagonal sockets 1/2"	10-11-12-13-14-15-16-17-18-19-21-22-24-27-30-32 mm	16
Hexagonal sockets 1/4"	4-4,5-5-5,5-6-7-8-9-10-11-12-13-14 mm	13
Extensions 1/2"	130-250 mm	2
Extensions 1/4"	55-100 mm	2
Reversible ratchet 1/2"		1
Reversible ratchet 1/4"		1
Spinner with handle 1/4"		1
Universal joint 1/2"		1
Universal joint 1/4"		1
Bit-holder socket	1/4-1/4"	1
Combination wrenches	8-9-10-11-12-13-14-15-16-17-18-19 mm	12
Adjustable wrench	250 mm	1
Screwdrivers for slot-head screws	0,4x2,5x50-0,5x3x75-0,8x4x100-1x5,5x125-1,2x6,5x150-1,6x8x175	6
Screwdrivers for PHILLIPS® screws	1x75-2x125	2
Screwdrivers for POZIDRIV®-SUPADRIV® screws	1x75-2x125	2
Angled hexagon keys	1,5-2-2,5-3-4-5-6-8-10 mm	9
Combination pliers	180 mm	1
Adjustable pliers	250 mm	1
Half-round pliers	160 mm	1
Diagonal cutting nippers	160 mm	1
Phase-testing screwdriver		1

DESCRIPTION	SIZE	PCS.
Scissors for electricians		1
Utility knife		1
Tape rule	3 m	1
Mini hacksaw frame		1
Hammer for mechanics	300 g	1
Bits for slot-head screws	3-4-4,5-5-5,5-6-6,5-7-8	9
Bits for PHILLIPS® screws PH	00-0-1(x2)-2(x2)-3-4	8
Bits for POZIDRIV®-SUPADRIV® screws PZ	1-2(x2)-3-4	5
Bits for hex socket screws	1,5-2-2,5-3-4-5-5,5-6-7-8 mm	10
Bits for hex socket screws	1/16-5/64-3/32-7/64-1/8-9/64-5/32-3/16-7/32-1/4	10
TORX® bits	T8-T9-T10-T15-T20-T25-T27-T30-T40-T45	10
TORX® Tamper Resistant bits	T8-T10-T15-T20-T25-T27-T30-T35-T45	9
Tri-Wing bits	1-2-3-4	4
Spanner bits	4-6-8-10-12	5
Torq bits	6-8-10	3
Square bits	0-1-2(x2)-3	5
Clutch bits	1/8-5/32-3/16-1/4-5/16	5
Bits XZN	M5-M6-M8	3
Hexagonal bits for hex socket screws with hole	2-2,5-3-4-5-6	6
Hexagonal bits for hex socket screws with hole	5/64-3/32-7/64-1/8-9/64-5/32	6
Magnetic extensions	1/4"	2





**174**  
PIECES

**002 JMP**  
U00020004

12 kg | 460 mm | 155 mm | 370 mm

### Case with assortment for maintenance, inch sizes

- Case with Aluminium section shell and metal reinforcements
- Double metal closing hinge with lock (key included)
- Handle with plastic protection
- Three internal panels equipped with elastics to hold tools
- Blocking system of the folding panel



606 1/2 APOL



606 1/4 APOL



692 J100



DESCRIPTION	SIZE	PCS.
Assortment with bihexagonal sockets in ABS case, in inches	606 1/2 APOL	15
Assortment with hexagonal sockets in ABS case, in inches	606 1/4 APOL	18
Phase-testing screwdriver 100÷250V	321 F	1
Half-round extra-long nose pliers with straight jaws	133 AX/160	1
Combination pliers	150 AX/180	1
Box-joint adjustable pliers	180 C/250	1
Heavy-duty diagonal cutting nippers	188 AX/160	1
Hacksaw frame with blade tensioner	201 S	1
Scissors for electricians	207 C	1
Utility knife with snap-off blades	220 B1	1

DESCRIPTION	SIZE	PCS.
Set of 8 long angled hexagon keys with spherical head, inch sizes	280 LTSP/S8	8
Combination wrenches, inch sizes	285 P / 1/4-5/16-3/8-7/16-1/2-9/16-5/8-11/16-3/4-13/16-7/8-15/16	12
Adjustable wrenches with quick adjustment	294 AD/250	1
Screwdrivers for slot-head screws	324 0,4x2,5x75-0,5x3x75-0,8x4x100-1x5,5x125-1,2x6,5x150-1,6x8x175	6
Screwdrivers for PHILLIPS® screws	324 PH / 1x75-2x125	2
Screwdrivers for POZIDRIV®-SUPADRIV® screws	324 PZ / 1x75-2x125	2
Hammers for mechanics	382/300	1
Assortment of bits with special shapes - 1/4"	692 J100	100
Professional tape rule with shockproof covering	981 A/3	1



**183**  
PIECES

**5**  
COMPARTMENTS

**646/5LM183**  
U06468002E

15 kg | 560 mm | 320 mm | 220 mm

### Long cantilever tool box, five compartments

- Preset for padlock
- Sheet steel casing, anaphoretic process
- Inside dimensions:  
lower compartment 537x207x100 mm,  
compartments 537x103x52 mm



DESCRIPTION	SIZE	PCS.
Assortment of bits with special shapes	692 J100	100
Assortment with hexagonal sockets	601 1/2 J22	22
Assortment with hexagonal sockets and bits	601 1/4 J34	34
Combination wrenches	285 J/B16 (6-7-8-9-10-11-12-13-14-15-16-17-18-19-22-24 mm)	16
Set with 5 screwdrivers	322 SH5 (322 0,6X3,5X75-0,8X4X100-1X5,5X100-322 PH 1X100-2X125)	5
Set with 2 pliers	150 AX/S2 (150 AX 180 - 180 C 250)	2
Hammer 400 gr	382/400	1
Scissors for electricians	207C	1
Mini hacksaw	201	1
Adjustable wrench 200 mm	294 A 200	1



420 mm

MAX  
11 kg

CAPACITY  
34 L

007/1V  
U00070001

2,5 kg | mm | 420  
340  
240



All equipment on hand

### Professional tool bag (empty)

- Model in high strength fabric
- Rigid waterproof bottom
- Inside space for tools
- Aluminium handle with covered handgrip
- 2 front pockets for small objects, 1 side pocket with Velcro closure, 1 side open pocket for quick access to contents, 4 rear pockets protected by the soft top
- 2 internal hooks for tape rule and 6 elastics to hold tools
- 1 pocket with 4 elastics to hold tools and 11 elastics for screwdrivers
- Soft top cover with Velcro



490 mm

MAX  
15 kg

CAPACITY  
47 L

007 V  
U00070002

4 kg | mm | 490  
350  
220



Front pocket for saw

### Professional tool bag (empty)

- Model in high strength fabric
- Rigid waterproof bottom
- Toolholder compartments and front pocket for a saw
- Aluminium handle with covered handgrip
- Transport shoulder strap
- Soft top cover with Velcro



550 mm

MAX  
18 kg

CAPACITY  
33 L

007 TXV  
U00070065

5,4 kg | mm | 550  
440  
360



Telescopic Aluminium handle

### Trolley tool bag (empty)

- Model in high strength fabric
- Telescopic Aluminium handle
- 6 external pockets and 1 front pocket for a saw
- Toolholder compartments
- Aluminium handle with covered handgrip
- Soft top cover with Velcro
- Maximum loading capacity: 18 kg



Front pocket for saw



Wheels with diameter 90 mm



MAX  
10 kg

CAPACITY  
15 L

**007 MCV**  
U00070008

1 kg | mm → 360  
↑ 280  
↙ 190

### Tool bag (empty)

- Model in high strength Fabric
- Rigid waterproof bottom
- Internal toolholder compartments
- 3 front pockets with soft top protections
- 3 back pockets
- Handles with PVC cover
- Transport shoulder strap



MAX  
9 kg

CAPACITY  
8 L

**007 FLV**  
U00070007

470 g | mm → 310  
↑ 220  
↙ 140

### Tool bag (empty)

- Model in high strength Fabric
- Frontal pocket with zipper closure
- Back pocket with velcro closure
- Rigid reinforced bottom
- Internal tool compartments
- Handles with PVC cover



MAX  
25 kg

CAPACITY  
9 L

**007 PLV**  
U00070034

1,7 kg | mm → 450  
↑ 170  
↙ 180

### Bag for plumbers (empty)

- High strength fabric
- Rigid riveted bottom for higher resistance
- Inside pocket for documents
- Can hold a 1.1/2" pipe wrench
- Outside hook for tape rule
- Removable shoulder strap for extra comfort during transport
- Two top handles for better grip
- Closure with Velcro and quick release snap buckles



# Portable storage

YouTube



MAX  
15 kg

CAPACITY  
8 L



Front opening for quick access to content



007 RV  
U00070033

1,8 kg | mm ↔ 460  
↓ 160 ↗ 350

### Bag for laptop and tools (empty)

- High strength fabric
- Rigid reinforced bottom
- The front opening allows quick access to content
- Padded compartment for notebook and documents (inside dimensions: 340x240 mm)
- 14 pockets, 2 tool straps and 1 hook for tape rule
- Removable shoulder strap for extra comfort during transport
- Closure with quick release snap buckles

MAX  
12 kg

CAPACITY  
30 L



Rear pocket for notebook and documents



007 SV  
U00070004

3,1 kg | mm ↔ 355  
↓ 225 ↗ 460

### Professional backpack (empty)

- High strength fabric
- Adjustable chest strap
- Padded waist straps to distribute the weight evenly
- Rigid waterproof bottom
- Inside tool-holding space
- Side and front pockets
- Inside document holder
- Padded compartment for notebook and documents (inside dimensions: 340x240 mm)
- Maximum loading capacity: 12 kg

007 TV  
U00070006

3,5 kg | mm ↔ 350  
↓ 500 ↗ 200

### Professional tool trolley (empty)

- Cabin size dimensions
- High strength fabric
- Inside toolholding spaces
- Front document pocket
- Side pockets with straps for long objects
- Telescopic Aluminium handle
- Wheels integrated into the structure
- Back shoulder straps
- Padded compartment for notebook and documents (inside dimensions: 340x240 mm)
- Maximum loading capacity: 14 kg



Rear pocket for notebook and documents



MAX  
14 kg

CAPACITY  
30 L



MAX  
20 kg

4,7 kg | mm | → 465  
↑ 352  
↘ 215



**001 RV**  
U00010004

**Tool case in high thickness polypropilene (empty)**

- Two inside removable panels with elastics to hold tools
- Lower compartment with mobile separators
- Double key lock

MAX  
20 kg

6 kg | mm | → 465  
↑ 352  
↘ 255



**001 TRV**  
U00010005

**Tool trolley in high thickness polypropilene (empty)**

- Telescopic Aluminium handle
- Wheels with integrated roll bearings



5  
COMPARTMENTS

6,6 kg | mm | → 560  
↑ 320  
↘ 220



**646/5LV**  
U06460301

**Long cantilever tool box, five compartments (empty)**

- Preset for padlock
- Sheet steel casing, anaphoretic process

8  
COMPARTMENTS

1,5 kg | mm | → 422  
↑ 106  
↘ 335



**640 A**  
U06400001

**Organizer (empty)**

- Transparent cover: contents visible
- 8 removable compartments one of which can be further divided with the 2 dividers provided

**641 T**

**Tool box (empty)**

- High resistant plastic material
- 2 compartments for small objects on the cover
- Possibility to close with a padlock (not supplied)
- Foldaway handle
- Inside removable tray

	CODE	L (mm)	P (mm)	H (mm)	kg
A	U06410004	16" 394	220	162	1,2 kg
B	U06410005	19" 486	266	236	2,1 kg
C	U06410006	24" 595	281	260	2,8 kg





## POWER ASSIST SCREWDRIVER 324 XP SPEED OF THE BATTERY, ACCURACY OF YOUR HAND



**LIGHT**  
with 5 frontal LED with automatic switch-off at 10 seconds.



**AUTOMATIC LOCKING SYSTEM**  
of the chuck to apply the torque by hand.



**MAGNETIC BIT HOLDER**  
with quick release chuck.



**HANDLE**  
ergonomic in oil and chemicals resistant rubber.

**IEC 60529**

CE  
**EN 60529**

**TECHNICAL CHARACTERISTICS**

Vibrations (mm/s <sup>2</sup> )	1,4
Sound power dB(A)	54
Dimensions (mm)	170x39
Weight (gr)	245



**LITHIUM**  
3.6V - 2.0 Ah  
lithium battery.

- <15%
- 15÷74%
- 75÷100%



**RECHARGEABLE**  
LED indicator of the battery charge status. Complete recharge in 70 minutes. (IN: 5V = 3A).

## POWER ASSIST SCREWDRIVER



**300 RPM**  
**0,9 Nm**

**ITS SPEED**  
Works with 300 rpm speed coming from the electric engine.

**YOUR ACCURACY**  
Close the tightening with the accuracy of a standard screwdriver.

**10 Nm**



High resistance nylon



Bits holding elastics



1/4

**324 XP/B16**  
**U03240801**

**16**  
PIECES

**Bag with power assist screwdriver and bits**

- High resistance nylon bag with belt hook
- Bits holder elastics and USB-C cable pocket



## SCREWDRIVERS 324 TOP PERFORMANCES



### THREE-MATERIAL GRIP

- 1 Outside part in polyurethane resistant to oils and chemicals.
- 2 Body in polyamide resistant to the efforts.
- 3 Inside part in high density polyamide for perfect coupling with the blade.

### REINFORCED BLADE

Chrome Silicon Vanadium steel that allows the best mechanical resistance.

### TOP PERFORMANCE TIP

Zinc finish. Perfect shape. Treatment against corrosion.

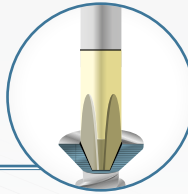

### ANTI-ROLLING SHAPE

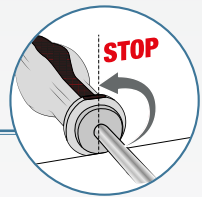

**SOFT GRIP COATING**  
Better comfort during the use.  
Greater transmission of the torque.



YouTube



### 324 SH5

U03240645

Set of 5 screwdrivers for slot-head and PHILLIPS® screws

- 324 D/0,8x4x100 - 1x5,5x125
- 324 PH/0x75 - 1x75 - 2x100

5  
PIECES



### 324 SH8

U03240650

Set of 8 screwdrivers for slot-head and PHILLIPS® screws

- 324 D/0,4x2,5x50
- 324/0,5x3x75-0,8x4x100-1x5,5x125-1,2x6,5x150
- 324 PH/0x75-1x75-2x100

8  
PIECES



### 324 SH12

U03240651

Set of 12 screwdrivers for slot-head, PHILLIPS® and POZIDRIV® -SUPADRIV® screws

- 324 D/0,4x2,5x50
- 324/0,5x3x75-0,8x4x100-1x5,5x125-1,2x6,5x150
- 324 N/1x5,5x35
- 324 PH/0x75-1x75-2x100
- 324 NPH/2x35
- 324 PZ/1x75-2x100

12  
PIECES



### 324 STX/S7

U03240662

Set of 7 screwdrivers for TORX® Tamper Resistant screws

- 324 STX/T10x75-T15x75-T20x100-T25x100-T27x100-T30x125-T40x150

7  
PIECES



## SCREWDRIVERS 322 QUALITY AND CONVENIENCE.



**7**  
PIECES



**322 SH7**  
U03220254

Set of 7 screwdrivers for slot-head and PHILLIPS® screws

- 322 0,4x2x50-0,5x3x75-0,8x4x100-1x5,5x100-1,2x6,5x150
- 322 PH/1x100-2x125



**10**  
PIECES



**322 SH10**  
U03220255

Set of 10 screwdrivers for slot-head, PHILLIPS® and POZIDRIV® screws

- 322 0,4x2x50-0,5x3x75-0,8x4x100-1x5,5x100-1,2x6,5x150
- 322 PH/OX75-1x100-2x125
- 322 PZ 1X100-2X125

## SCREWDRIVERS 091 1000V INSULATION - EN 60900.

**USAG SLIM**



**5**  
PIECES

**091 D/SH5**  
U00910119

Set of 5 SLIM screwdrivers for slot-head and PHILLIPS® screws - 1000 V

- 091 D/0,6x3,5x100-0,8x4x100-1x5,5x125
- 091 DPH/1x100-2x125



**5**  
PIECES

**091 SH5**  
U00910100

Set of 5 screwdrivers for slot-head and PHILLIPS® screws - 1000 V

- 091/0,5x3x75-0,8x4x100-1x5,5x125
- 091 PH/1x100-2x125



**8**  
PIECES

**091 SH8**  
U00910106

Set of 8 screwdrivers for slot-head and PHILLIPS®, POZIDRIV® - SUPADRIV® screws - 1000 V

- 091/0,5x3x75-0,8x4x100-1x5,5x125-1,2x6,5x150
- 091 PH/1x100-2x125
- 091 PZ/1x100-2x125



# Hexagonal keys and bits



YouTube

8  
PIECES

1/4"

**RATCHET SYSTEM**



**333 K/SH8**

U03330142



**COMBIDRIVE set with bits**

- Delivered with 6 different bits 1/4"

DESCRIPTION	ITEM/SIZE	PCS.
COMBIDRIVE handgrip with 3 functions	333 K	1
COMBIDRIVE magnetic bit-holder	333 1/4 MG	1
Bits for slot-head screws -1/4"	660/0,6x4,5-1x5,5	2
Bits for PHILLIPS® screws -1/4"	660 PH 1-2	2
Bits for hex socket screws -1/4"	660 E 3-4	2



**RATCHET SYSTEM**



USAG 660 bits not included

10  
PIECES

1/4"

**333 K/SB10**

U03330143



**COMBIDRIVE set in nylon bag**

- Delivered with 8 different blades
- Nylon bag with belt hook

DESCRIPTION	ITEM/SIZE	PCS.
COMBIDRIVE handgrip with 3 functions	333 K	1
COMBIDRIVE magnetic bit-holder	333 1/4 MG	1
Reversible COMBIDRIVE blades for slot-head screws	333 I 0,6x3,5-0,8x4/1x5,5-1,2x6,5	2
Reversible COMBIDRIVE blades for PHILLIPS® screws	333 PH 0-1/2-3	2
Reversible COMBIDRIVE blades for TORX® screws	333 TX T8-T9	4
	333 STX T10-T15/T20-T25/T30-T40	



YouTube

**210 mm length**



**280 TQ**

U02800800

**T-key bit holder**

- Double magnetic bit-holder 1/4"
- Maximum capacity of the bit-holder: 6 mm hexagonal bit or T40 Torx bit
- Single end with 1/4" sockets square drive
- Special Chrome Vanadium steel
- Chrome plated finish

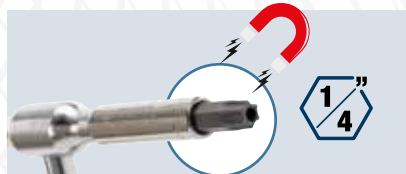

**DOUBLE MAGNETIC BIT-HOLDER 1/4"**



**1/4" SOCKETS SQUARE DRIVE**

**XGRIP**

**DISCOVER THE X-GRIP RANGE**

Go to page 4



YouTube

## KEY 280 T GUARANTEED SAFETY



**SPECIAL CHROME  
VANADIUM STEEL**

**FIX BAR**  
Maximum resistance.



**USAG KEY**



**OTHER KEYS**

### GUARANTEED SAFETY

- + 30% resistance to torsion compared to ISO 2936 rules.
- When the breaking torque is reached, the key will deform without breaking.

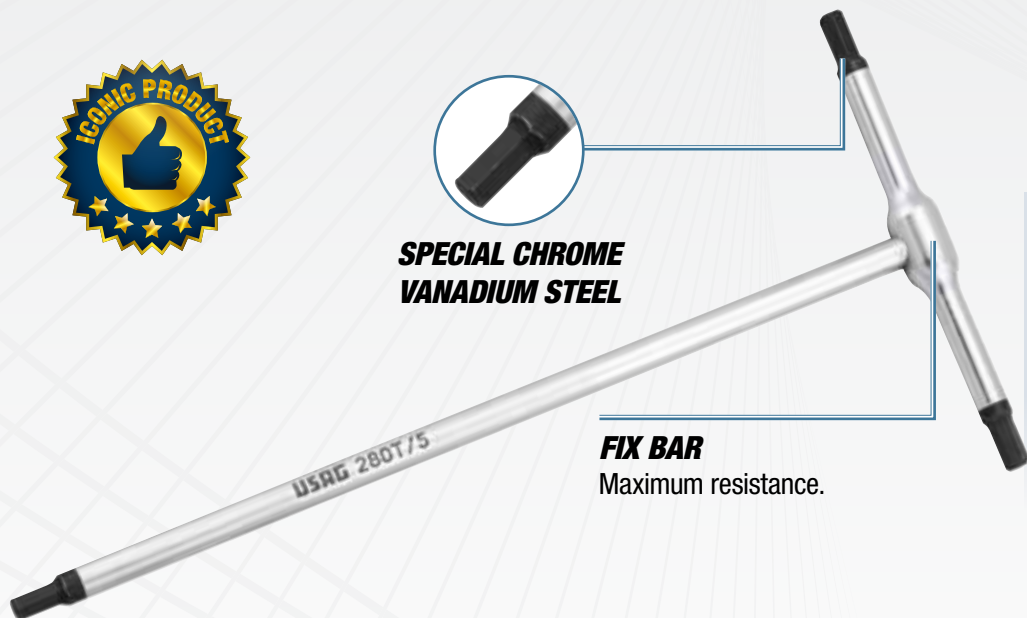

**7  
PIECES**



**280 T/SE7**  
U02800903

**Set of 7 T-handle hexagon keys**  
• 280 T/2-2,5-3-4-5-6-8 mm



**8  
PIECES**



**280 TTX/SE8**  
U02800686

**Set of 8 T-handle keys for TORX® screws**  
• 280 TTX/T6-T7-T8-T9-T10-T15-T20-T25



**6  
PIECES**



**280 TTS/SE6**  
U02800760

**Set of 6 T-handle hexagon keys with spherical head**  
• 280 TTS/2,5-3-4-5-6-8 mm



**Spherical head**

**6  
PIECES**



**280 TK/SE6**  
U02800020

**Set of 6 T-handle hexagon keys with sliding bar**  
• 280 TK/2,5-3-4-5-6-8 mm



**Sliding bar**

## ANGLED HEXAGON KEYS 280 HG WITH HANDGRIP



### GUARANTEED SAFETY

- + 30% resistance to torsion compared to ISO 2936 rules.
- When the breaking torque is reached, the key will deform without breaking.

**Same blade as the 280 T keys**



**ERGONOMIC BIMATERIAL HANDGRIP**

**SPECIAL CHROME VANADIUM STEEL**



**6**  
PIECES



**280 HG/SE6**  
U02801460

Set of 6 angled hexagon keys with bimaternal handgrip

- 280 HG/2,5-3-4-5-6-8 mm

**6**  
PIECES



**280 HGTS/SE6**  
U02801463

Set of 6 angled hexagon keys with spherical head and bimaternal handgrip

- 280 HG/2,5-3-4-5-6-8

**Spherical head**



**6**  
PIECES



**280 HAP/SE6**  
U02800462

Set of 6 angled hexagon keys with handgrip, inch sizes

- 280 HAP 1/4-7/32-5/32-5/16-3/8-3/16

**6**  
PIECES



**280 HATX/SE6**  
U02800464

Set of 6 angled keys with handgrip for TORX® screws

- 280 HATX/T8-T10-T15-T20-T25-T30



# Hexagonal keys and bits



**32**  
PIECES



280 g | mm | 138  
30  
98



YouTube



**49**  
PIECES



280 g | mm | 138  
30  
98



## 692 J32 U06920042

Assortment with bits and reversible ratchet - 1/4"

DESCRIPTION	SIZE	PCS.
Bits for slot-head screws	4-5,5-6,5-8	4
Bits for PHILLIPS® screws	PH 1-2-3	3
Bits for POZIDRIV® screws	PZ 1-2-3	3
Bits for hex socket screws	3-4-5-6	4
Bits for TORX® screws	T8-10-15-20-20-25-25-30-40	9
Bits for TORX® Tamper Resistant screws	STX 10-15-20-25-27-30-40	7
Magnetic bit-holder adapter		1
Ratchet		1

## 692 J49 U06920041

Assortment with bits - 1/4"

DESCRIPTION	SIZE	PCS.
Bits for slot-head screws	4-4,5-5,5-6,5-6,5-8	6
Bits for PHILLIPS® screws	PH 1-1-2-2-2-3	6
Bits for POZIDRIV® screws	PZ 1-1-2-2-2-3-3	7
Bits for hex socket screws	2-3-3-4-4-5-5-6-6	9
Bits for TORX® screws	TX 10-10-15-15-20-20-25-25-30-30	10
Bits for TORX® Tamper Resistant screws	STX 10-15-15-20-20-25-25-30-30-40	10
Magnetic bit-holder adapter		1



Colour code for quick identification of the bit



50 mm



## 664 S25 U06640111

**25**  
PIECES



800 g | mm | 215  
45  
150

Assortment with long bits for impact wrenches - 1/4"  
• Plastic box

DESCRIPTION	SIZE	PCS.
Bits for slot-head screws	3-4-5-6	4
Bits for PHILLIPS® screws	1-2(x2)-3(x1)	5
Bits for POZIDRIV® screws	1-2(x2)-3(x1)	5
Bits for TORX® screws	T15-T20-T25-T30-T40	5
Bits for hex socket screws	2-3-4-5-5,5	5
Magnetic bit-holder adapter		1

## 664 B/S7 U06640015

Assortment with magnetic socket bits for hexagonal screws 1/4"

• Compact plastic box



**7**  
PIECES



**5,5-6-7-8  
10-12-13 mm**

300 g | mm | 138  
30  
98



# Hexagonal keys and bits



900 g | 215 mm  
45 mm | 150 mm

DESCRIPTION	SIZE	PCS.
Bits for slot-head screws	3-4-4,5-5-5,5-6-6,5-7-8	9
Bits for PHILLIPS® screws	PH 00-0-1-1-2-2-3-4 PZ 1-2-2-3-4	13
Bits for hex socket screws	1,5-2-2,5-3-4-5-5,5-6-7-8 mm 1/16-5/64-3/32-7/64-1/8-9/64-5/32-3/16-7/32-1/4"	20
Bits for TORX® screws	T 8-9-10-15-20-25-27-30-40-45	10
Bits for TORX® Tamper Resistant screws	STX 8-10-15-20-25-27-30-35-40	9
Tri-Wing bits	1-2-3-4	4
Spanner bits	4-6-8-10-12	5
Torq-set bits	6-8-10	3
Square bits	0-1-2-2-3	5
Clutch bits	1/8-5/32-3/16-1/4-5/16	5
Bits XZN	M5-M6-M8	3
Bits for hex socket screws with hole	2-2,5-3-4-5-6 mm - 5/64-3/32-7/64-1/8-9/64-5/32"	12
Magnetic bit-holder adapter	1/4x60mm	2

**692 J100**  
U06920043

Assortment of bits with special shapes - 1/4"

100  
PIECES

1/4



**COMPACT SUPPORTS WITH QUICK EXTRACTION SYSTEM**



Watch the video



YouTube



9  
PIECES



**280 LTS/S9**  
U02800084

Set of 9 long angled hexagon keys with spherical head

- 280 LTS/1,5-2-2,5-3-4-5-6-8-10 mm



8  
PIECES



**280 LTSTX/S8**  
U02800078

Set of 8 long angled keys with spherical head for TORX® screws

- 280 LTSTX/T10-T15-T20-T25-T27-T30-T40-T45



**Extra long model +30% of the standard 280 LTS**

9  
PIECES



**280 XLTS/S9**  
U02800184

Set of 9 long hexagon keys with spherical head

- 280 XLTS/1,5-2-2,5-3-4-5-6-8-10 mm

**XGRIP**



**DISCOVER THE X-GRIP RANGE**

Go to page 4

## RANGE OF PLIERS "AX" CHROME PLATED FINISH. BIMATERIAL HANDLES.



Can cut up to 2 mm piano wire with 30% less effort in comparison to the maximum value stated on the European rules ISO5749 (cutting nippers) - ISO5746 (pliers)

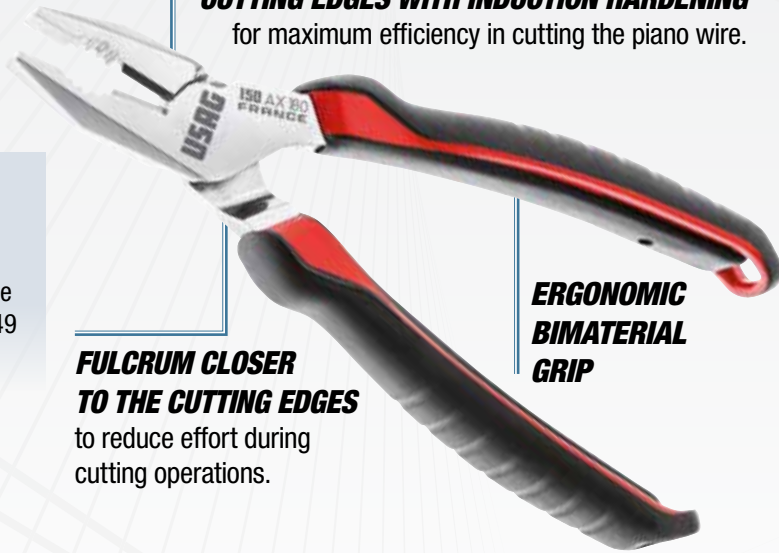

**CUTTING EDGES WITH INDUCTION HARDENING**  
for maximum efficiency in cutting the piano wire.

**FULCRUM CLOSER TO THE CUTTING EDGES**  
to reduce effort during cutting operations.

**ERGONOMIC BIMATERIAL GRIP**

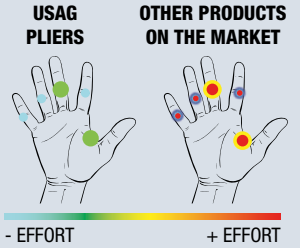

Minimum effort resulting from the studies on muscle strain made by the prestigious US Ergonomics Institute

**3**  
PIECES



**150 AX/SE3**  
U01500201

**Assortment with combination pliers, extra-long half-round nose pliers and cutting nippers**

- Combination pliers 150 AX 180
- Half-round extra-long nose pliers with straight jaws 133 AX 160
- Diagonal cutting nippers 188 AX 160

**3**  
PIECES



**085 EX/SE3**  
U00850121

**Assortment with combination pliers, half-round nose pliers with straight jaws and diagonal cutting nippers - 1000 V**

- Half-round extra-long nose pliers with straight jaws 081 EX 160
- Combination pliers 085 EX 180
- Diagonal cutting nippers 087 EX 160

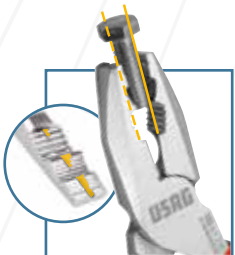

**ROUND PROFILES**

Special notch on the toothing for a strong grip of round bars, also threaded

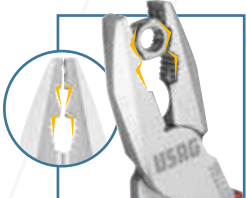

**HEXAGONAL PROFILES**

Jaw shape studied to grip hexagonal material



**155 AX**  
U01550001

**Multifunction combination pliers**

**Multifunction combination pliers**



**MAX. CAPACITY**  
80 mm

**135 B**  
U01350510

**Lock-grip rack-type pliers with long jaws**

- Forged jaws
- Tothing designed for a perfect grip even on round surfaces
- Patented opening system integrated in the handles
- Roller grip adjustment integrated in the handle
- 5-positions rack

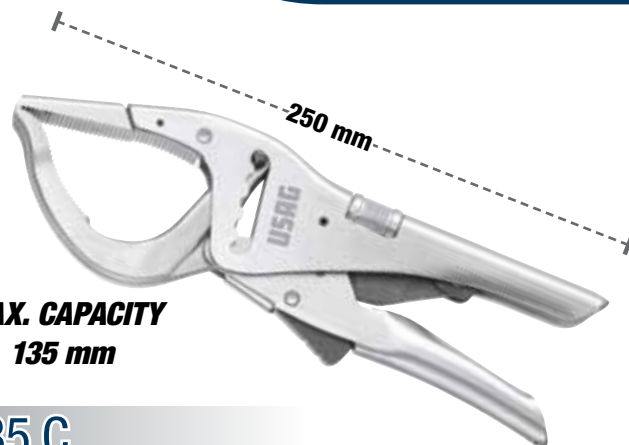

**MAX. CAPACITY**  
135 mm

**135 C**  
U01350530

**Lock-grip rack-type pliers with long jaws**

- Forged jaws
- Tothing designed for a perfect grip even on round surfaces
- Patented opening system integrated in the handles
- Roller grip adjustment integrated in the handle
- 5-positions rack



**FLUSH CUT**



**FOR PLASTICS**

**186 C**

**Diagonal cutting nippers with flush cutting edge for plastics**

- Rounded thinned jaws
- Spring-action
- Handles sheathed in PVC

CODE	L	
U01860060	150 mm	22 mm
U01860061	180 mm	27 mm



**FLUSH CUT**  
**BENT AT 45°**



**FOR PLASTIC**

**187 C**  
U01870001

**Diagonal cutting nipper bent at 45° with flush cutting edge for plastics**

- Rounded thinned jaws
- Spring-action
- Handles sheathed in PVC
- Special Chrome Vanadium steel
- Burnished finish with polished head

**FOR THE SMOOTH, FLUSH CUTTING OF SPRUE  
AS ARISES DURING INJECTION MOULDING**

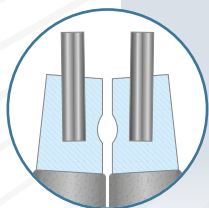

## MAXIMUM RESISTANCE

Spring steel tips inserted into the nose.

**4**  
PIECES



**127 N/SE4S**  
U01270046

**10÷25 mm**

**Set of 4 pliers for circlips**

- Pliers for internal circlips **127 N** 12÷25, **127 PN** 12÷25, pliers for external circlips **128 N** 10÷25, **128 PN** 10÷25

**127 N/SE4**  
U01279000P

**19÷60 mm**

**Set of 4 pliers for circlips**

- Pliers for internal circlips **127 N** 19-60, **127 PN** 19-60, pliers for external circlips **128 N** 19-60, **128 PN** 19-60

**127 C/SE4S**  
U01270045

**10÷25 mm**

**Set of 4 pliers for circlips**

- Pliers for internal circlips **127 C** 12÷25, **127 CP** 12÷25, pliers for external circlips **128 C** 10÷25, **128 CP** 10÷25

**127 C/SE4**  
U01270040

**19÷60 mm**

**Set of 4 pliers for circlips**

- Pliers for internal circlips **127 C** 19-60, **127 CP** 19-60, pliers for external circlips **128 C** 19-60, **128 CP** 19-60

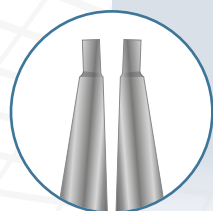

## MAXIMUM ACCESSIBILITY

Nose and tip in a single body.

**4**  
PIECES



**127 C/SE4P**  
U01270060

**3÷10 mm**



**Set of 4 pliers for circlips**

- Pliers for internal circlips **127 C** 3÷10-**127 CP** 3÷10.
- Pliers for external circlips **128 C** 3÷10-**128 CP** 3÷10.

**127 C/SE4M**  
U01270065

**40÷100 mm**



**Set of 4 pliers for circlips**

- Pliers for internal circlips **127 C** 40÷100-**127 CP** 40÷100.
- Pliers for external circlips **128 C** 40÷100-**128 CP** 40÷100.



## RACK-TYPE PLIERS

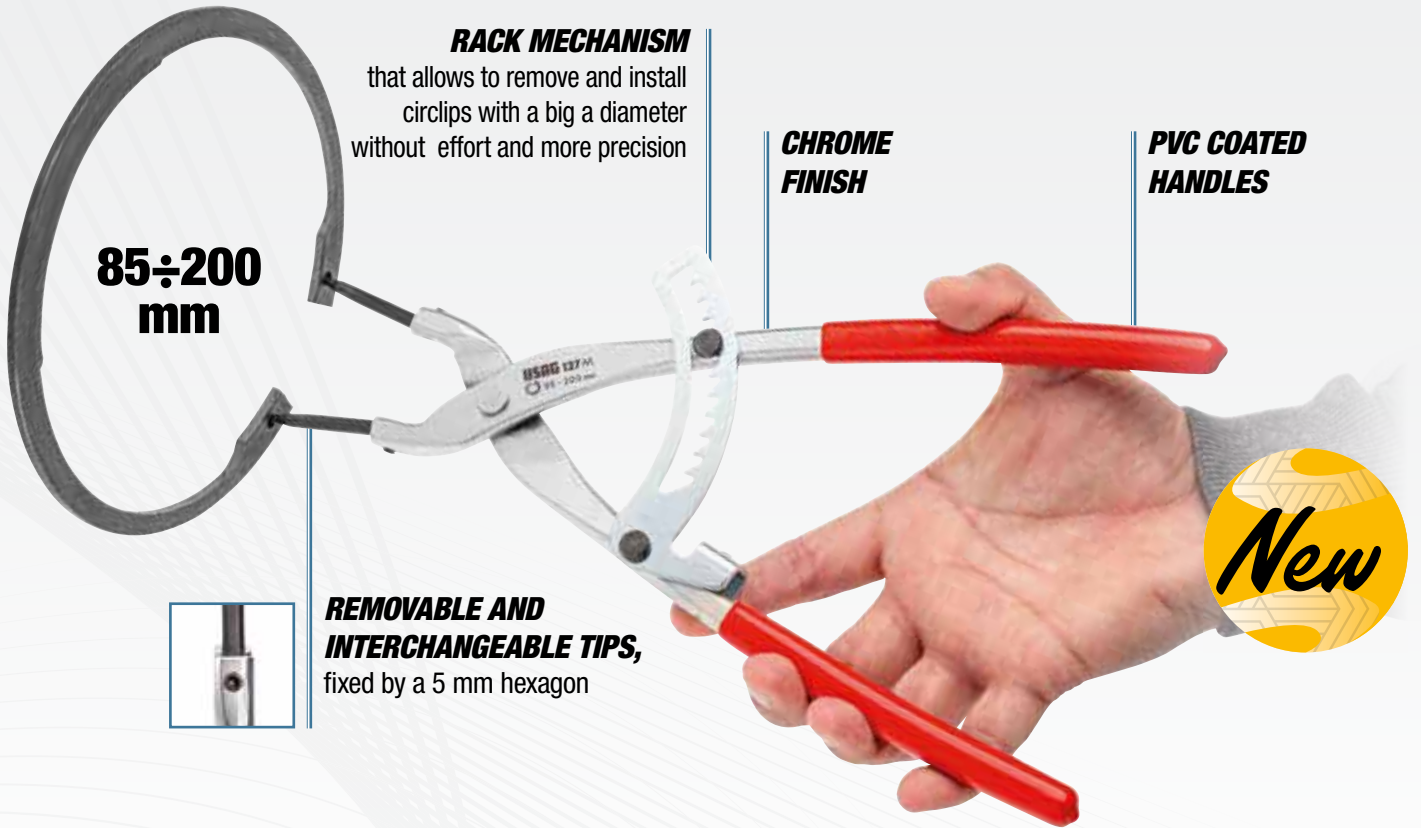

**RACK MECHANISM**  
that allows to remove and install  
circlips with a big a diameter  
without effort and more precision

**CHROME  
FINISH**

**PVC COATED  
HANDLES**

**85÷200  
mm**

**REMOVABLE AND  
INTERCHANGEABLE TIPS,**  
fixed by a 5 mm hexagon

**New**

**New**

**127 M**  
U01270051

Rack-type plier with straight  
nose for internal circlips with  
big dimensions

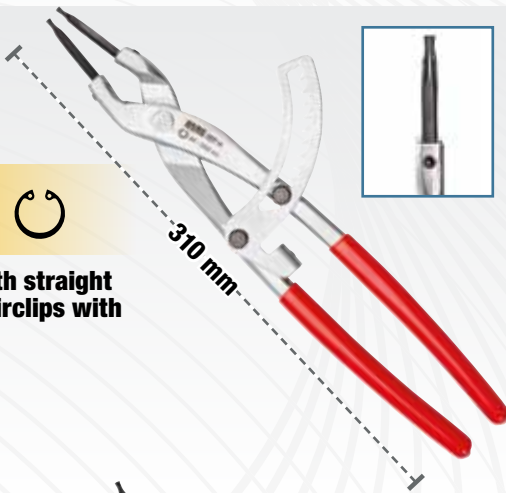

**New**

**127 MP**  
U01270050

Rack-type plier with nose bent  
at 45° for internal circlips with  
big dimensions

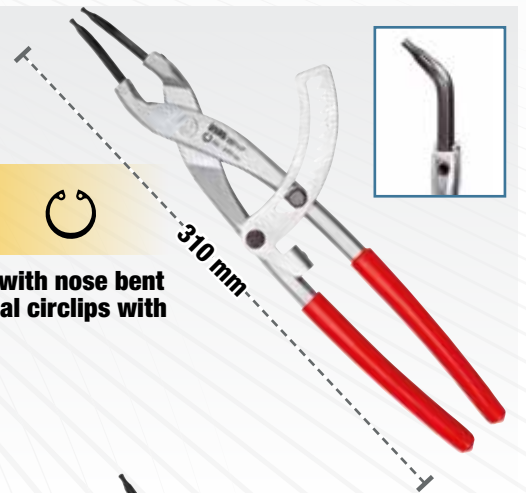

**New**

**128 M**  
U01280051

Rack-type plier with straight  
nose for external circlips with  
big dimensions

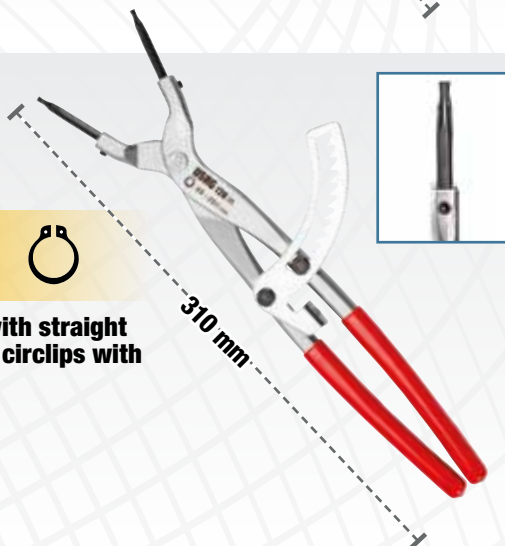

**New**

**128 MP**  
U01280050

Rack-type plier with nose bent  
at 45° for external circlips with  
big dimensions

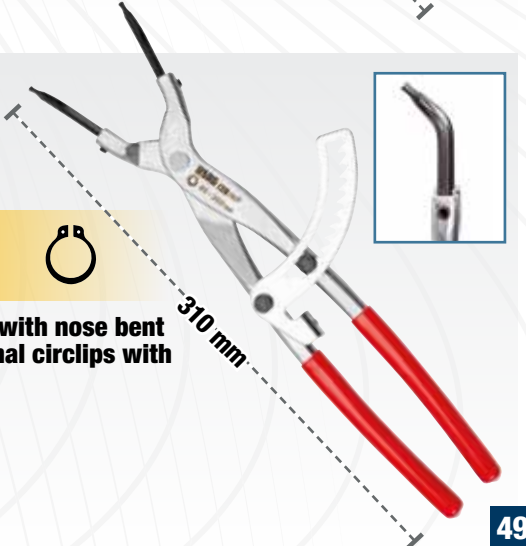

## PLIER WRENCH 174 CX PLIER AND WRENCH IN THE SAME TOOL



**QUICK ADJUST CLOSING**  
without pushing the button.



**PARALLEL JAWS**  
Internal design that fits perfectly  
the hexagon.



**FLAT JAWS**

**MAX. CAPACITY**  
**58 mm**

**METRIC SCALE**

**20 POSITIONS RAIL**



 YouTube



**PVC COVERED  
HANDLES**

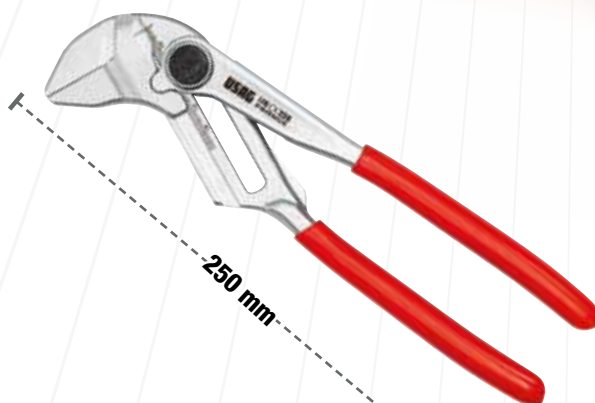

**174 CX**  
**U01740001**

- Adjustable plier wrench

**LARGE OPENING CAPACITY +20%**

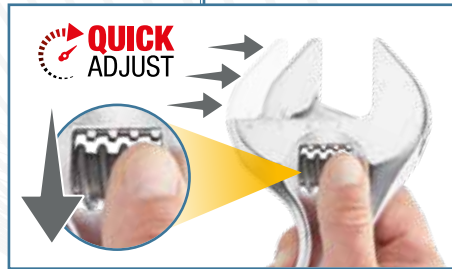

**QUICK ADJUSTMENT  
BY PULLING BACK THE ROLL**

**PRECISE REGULATION  
BY ROTATING THE ROLL**

**LARGE OPENING CAPACITY +20%**



**STANDARD  
POSITION**

**REVERSED  
JAW**

**REVERSE THE  
MOVABLE JAW**  
to drive an hexagonal  
or a round profile



**MAX  
OPENING  
34 MM**

**Only 150 mm**



**-46%**

**LENGTH REDUCED OF  
46% COMPARED TO A  
STANDARD WRENCH**

## 294 AD

### Adjustable wrenches with quick adjustment

- Quick adjustment by pulling back the roll
- Large capacity: opening +20% compared to the standard
- Double graduated scale: millimetres and inches
- Head angled at 22°
- Steel roll
- Hanging hole
- Chrome plated finish

CODE	L	OPENING
U02940011	110 mm - 4"	17 mm
U02940012	150 mm - 6"	23 mm
U02940013	200 mm - 8"	33 mm
U02940014	250 mm - 10"	38 mm
U02940015	300 mm - 12"	41 mm
U02940016	380 mm - 15"	50 mm
U02940017	460 mm - 18"	63 mm

## 294 AG

### Reversible adjustable wrenches with handle

- In the standard position it can drive a hexagonal profile
- By reversing the movable jaw, it can drive a round profile
- Large capacity: opening +20% compared to the standard
- Double graduated scale: millimetres and inches
- Ergonomic bimaterial handle
- Head angled at 22°
- Steel roll
- Hanging hole
- Chrome plated finish

CODE	L	OPENING
U02940023	200 mm - 8"	33 mm
U02940024	250 mm - 10"	38 mm
U02940025	300 mm - 12"	41 mm

## 294 AC

U02940010

### Short adjustable wrench

- Length reduced of 46% compared to a standard wrench
- Same jaw opening of a 12" wrench
- Lightweight and compact for optimum accessibility
- Regulation by steel roll
- Scale in millimeters on the wrench head
- Chrome plated finish

## REVERSIBLE RATCHET COMBINATION WRENCHES 285 KA WITH LOCKING RING.

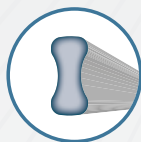
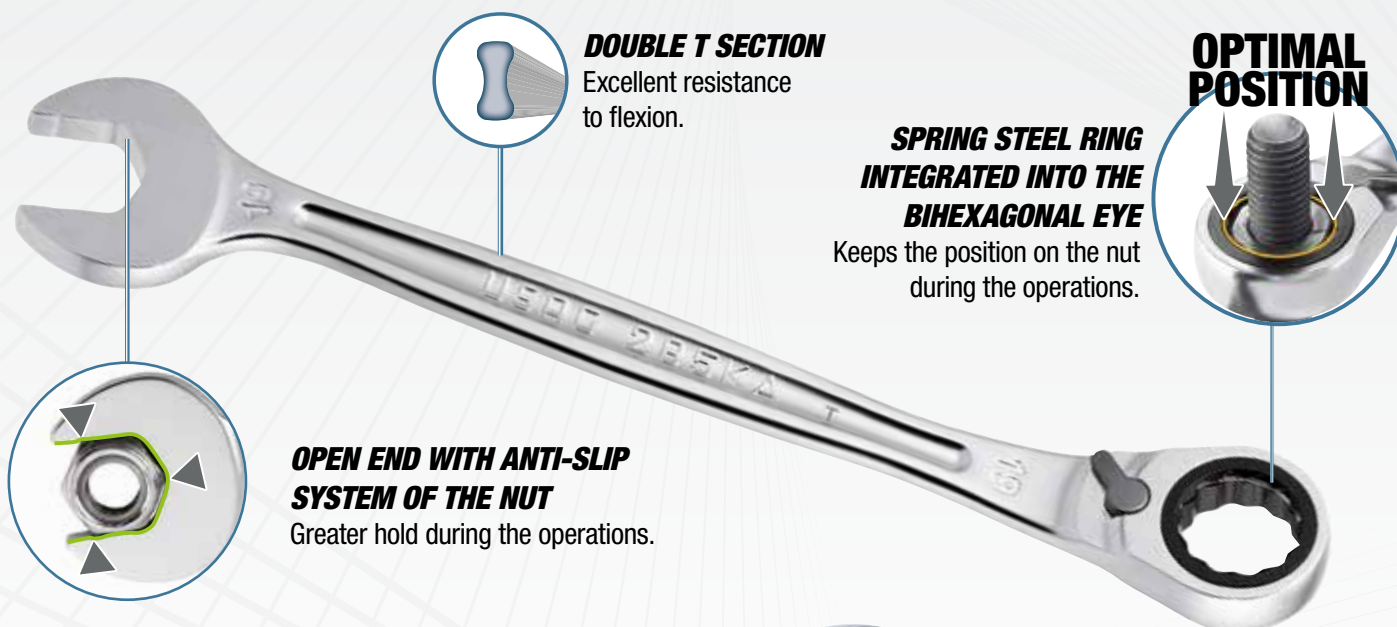

**DOUBLE T SECTION**  
Excellent resistance to flexion.

**OPTIMAL POSITION**



**SPRING STEEL RING INTEGRATED INTO THE BIHEXAGONAL EYE**  
Keeps the position on the nut during the operations.



**OPEN END WITH ANTI-SLIP SYSTEM OF THE NUT**  
Greater hold during the operations.

### STRONG RATCHET

The ratcheting ring of USAG wrenches 285 KA exceeds static torsion tests, reaching a torque of +50% compared to the value required by ISO rules 1711-1

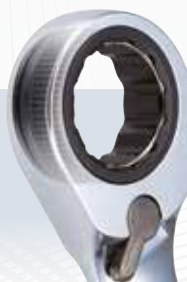

YouTube

**8**  
PIECES

**8÷19 mm**



**285 KA/DS8**

**U02856058**

**Set of 8 reversible ratchet combination wrenches with locking ring**

- 285 KA 8-10-11-12-13-14-17-19 mm
- Supplied with plastic holder

**12**  
PIECES

**7÷19 mm**



**285 KA/DS12**

**U02856062**

**Set of 12 reversible ratchet combination wrenches with locking ring**

- 285 KA/7-8-10-11-12-13-14-15-16-17-18-19 mm
- Supplied with plastic holder

## HINGED JOINTED REVERSIBLE RATCHET COMBINATION WRENCH 285 KF

**DOUBLE T SECTION**  
Excellent resistance to flexion.

**JOINTED HEAD**  
180°

**OPEN END WITH ANTI-SLIP SYSTEM OF THE NUT**  
Greater hold during the operations.

**5**  
PIECES

**8÷19 mm**

**285 KF/SE5**  
U02856160

**Set of 5 hinged jointed reversible ratchet combination wrenches**

- 285 KF 8-10-13-17-19 mm

**8**  
PIECES

**8÷19 mm**

**285 KF/DS8**  
U02856158

**Set of 8 hinged jointed ratchet combination wrenches**

- 285 KF 8-10-11-12-13-14-17-19 mm
- Supplied with plastic holder

## 285 KB FLAT RATCHET COMBINATION WRENCH

**FLAT RATCHET HEAD**  
ideal for hard to reach places

**CHANGE OF ROTATION**  
turning the wrench 180°

**7**  
PIECES

**8÷19 mm**

**285 KB/DS7**  
U02856341

**Set of 7 flat ratchet combination wrenches**

- 285 KB/8-10-12-13-14-17-19 mm.
- Supplied with plastic holder

**12**  
PIECES

**8÷19 mm**

**285 KB/DS12**  
U02856342

**Set of 12 flat ratchet combination wrenches**

- 285 KB/8-9-10-11-12-13-14-15-16-17-19 mm.
- Supplied with plastic holder



YouTube

## COMBINATION WRENCH 285 RESISTANCE AND ERGONOMIC.

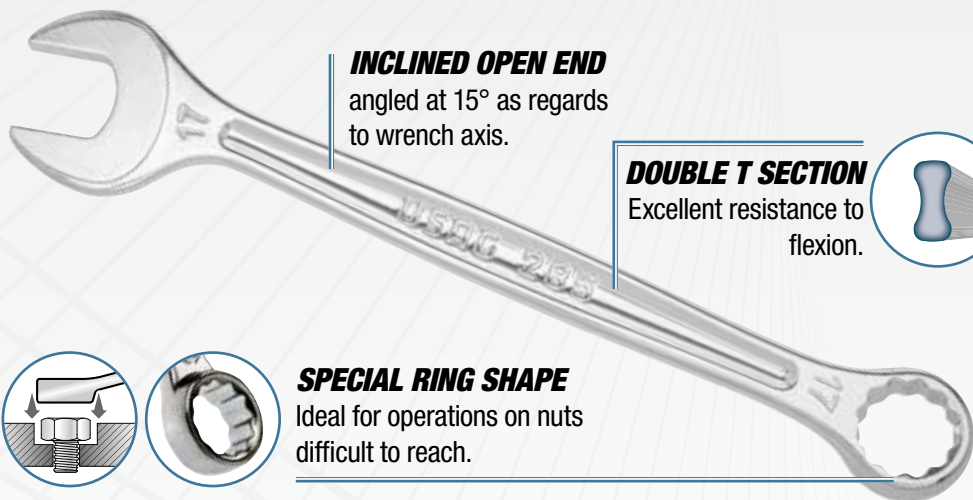

### INCLINED OPEN END

angled at 15° as regards to wrench axis.

### DOUBLE T SECTION

Excellent resistance to flexion.

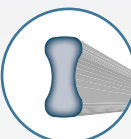

### SPECIAL RING SHAPE

Ideal for operations on nuts difficult to reach.



### TOP PERFORMANCE

The open end and the bihexagonal ring of the combination wrench 285 exceed the static torsion test, reaching a torque of +50% compared to the test value required by the standard ISO 1711-1

## ISO 1711-1 SAE AS 954E

8÷19 mm

8  
PIECES

### 285 DS8

U02850863

- Set of 8 combination wrenches
- 285/8-10-11-12-13-14-17-19 mm
  - Supplied with plastic holder

12  
PIECES

### 285 DS12

U02850864

- Set of 12 combination wrenches
- 285/7-8-10-11-12-13-14-15-16-17-18-19 mm
  - Supplied with plastic holder

7÷19 mm

SIZE  
IN INCHES

1/4÷9/16"



5  
PIECES

### 285 P/SE5

U02850856

- Set of 5 combination wrenches, inch sizes
- 285 P 1/4-3/8-7/16-1/2-9/16"



26  
PIECES

### 285 SE26

U02850861

- Set of 26 combination wrenches
- 285/6-7-8-9-10-11-12-13-14-15-16-17-18-19-20-21-22-23-24-25-26-27-28-29-30-32 mm

**XGRIP**

## DISCOVER THE X-GRIP RANGE

Go to page 4

Just **USAG**

## 285 J COMBINATION WRENCH



**OPEN END ANGLED  
AT 15°**



**BIHEXAGONAL HEAD  
BENT AT 15°**

**7**  
PIECES



**8÷19 mm**

**285 J/DS7**  
U02851745

**Set of 7 combination wrenches**

- 285 J/8-10-12-13-14-17-19 mm.
- Supplied with plastic holder

**12**  
PIECES



**8÷19 mm**

**285 J/DS12**  
U02851746

**Set of 12 combination wrenches**

- 285 J/8-9-10-11-12-13-14-15-16-17-19 mm.
- Supplied with plastic holder

**8**  
PIECES



**6÷22 mm**



**252 N/SR8**  
U02520862

**Set of 8 double ended open jaw wrenches**

- 252 N/6x7-8x9-10x11-12x13-14x15-16x17-18x19-20x22 mm

**8**  
PIECES



**7÷19 mm**

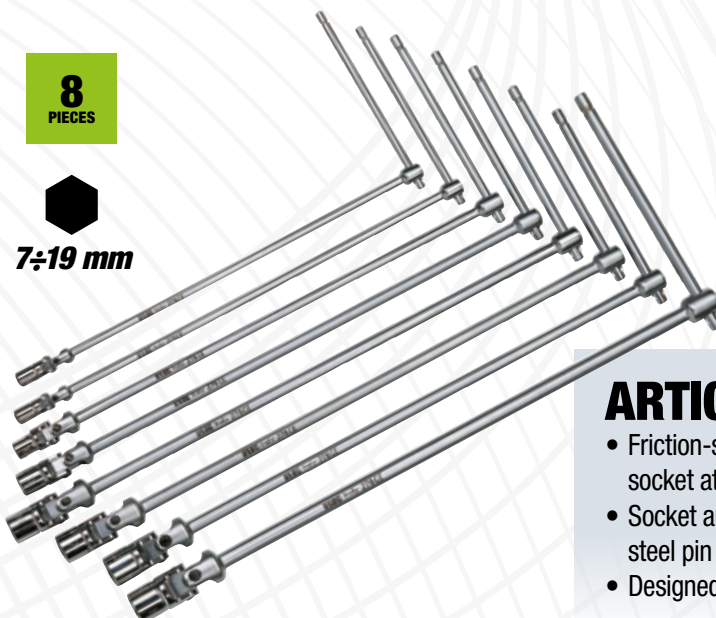

**UNI 6743**

**276 CE/SE8**  
U02760484

**Set of 8 T-handle wrenches with jointed hexagonal socket**

- 276 CE/7-8-10-12-13-14-17-19 mm

### ARTICULATED JOINT

- Friction-spring to allow presetting of the socket at the desired angle
- Socket and joint are fixed with a riveted steel pin for great stability.
- Designed and manufactured according to UNI 6743 rules.



# Ratchets and sockets

YouTube



Just **USAG**



**16**  
PIECES

1/4"

1/2"



1 kg | mm | 190  
58  
144

## 601 1/4-1/2" JTX16

U06010009

Assortment with TORX® sockets in modular box

DESCRIPTION	SIZE	PCS.
TORX® sockets 1/4"	E6-E7-E8-E10	4
TORX® sockets 1/2"	E12-E14-E16-E18	4
TORX® socket bits 1/4"	T10-T15-T20-T25	4
TORX® socket bits 1/2"	T30-T40-T45-T50	4



**34**  
PIECES

1/4"



1 kg | mm | 190  
58  
144

## 601 1/4" J34

U06010001

Assortment with hexagonal sockets and bits in modular box

DESCRIPTION	SIZE	PCS.
Hexagonal sockets 1/4"	4-4,5-5-5,5-6-7-8-9-10-11-12-13-14	13
Reversible ratchet 1/4"		1
Spinner with handle 1/4"		1
Extensions 1/4"	55-100	2
Bits for slot-head screws 1/4"	4-5,5-6	3
Bits for PHILLIPS® screws 1/4" PH	1-2-3	3
Bits for hexagonal screws 1/4"	4-5-6	3
TORX® bits 1/4"	T10-T15-T20-T25-T30-T40	6
Universal joint 1/4"		1
Bit-holder socket 1/4-1/4"		1



**22**  
PIECES

1/2"



4 kg | mm | 375  
80  
186

## 601 1/2" J22

U06010003

Assortment with hexagonal sockets in modular box

DESCRIPTION	SIZE	PCS.
Hexagonal sockets 1/2"	8-10-11-12-13-14-15-16-17-18-19-21-22-24-27-30-32	17
Reversible ratchet 1/2"		1
Extensions 1/2"	130-250	2
Universal joint 1/2"		1
T-handle 1/2"		1



**USAG** QUALITY AT A *Just* PRICE



1/4"

1/2"

8 kg | 415 mm | 92 | 283

**100**  
PIECES



**601 1/4-1/2" J100**

**U06010011**

Assortment with hexagonal sockets and bits in modular box



The boxes are modular with USAG roller cabinet drawers



1/4"

1/2"

7 kg | 415 mm | 92 | 283

**82**  
PIECES



**601 1/4-1/2" J82**

**U06010010**

Assortment with hexagonal sockets and combination wrenches in modular box



The boxes are modular with USAG roller cabinet drawers



## REVERSIBLE RATCHET 237 A WITH SEALED MECHANISM IP51.



Inversion system integrated into the cover



Head thickness reduced, compared to standard models



YouTube



**CONICAL HANDLE** in anti-slip bimaterial.

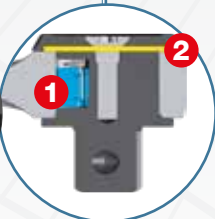

1. New patented pawl
2. Protective diaphragm

### TOP PERFORMANCE

1. Static torsional resistance: **+30% compared to the value required by ISO 3315 rules, with the patented pawl.**
2. Effort resistance: **assures twice the tightening cycles compared to standard products on the market, with IP51 protection.**



**23**  
PIECES

**1 1/2"**



3 kg | 330 mm | 215

**606 1/2" EA**  
U06060302

#### Assortment with hexagonal sockets in ABS case

- High resistance ABS case with quick closing system

DESCRIPTION	ITEM/SIZE	PCS.
Hexagonal sockets	235 1/2 EN 8-9-10-11-12-13-14-15-16-17-18-19-21-22-23-24-27-30-32	19
Extensions	236 1/2 125-250	2
Universal joint	241 1/2	1
Reversible ratchet with sealed mechanism (certified IP51)	237 A 1/2	1



**19**  
PIECES

**1 1/4"**



1 kg | 210 mm | 130

**606 1/4" EA**  
U06060101

#### Assortment with hexagonal sockets in ABS case

- High resistance ABS case with quick closing system

DESCRIPTION	ITEM/SIZE	PCS.
Hexagonal sockets	235 1/4 EN 4-4.5-5-5.5-6-7-8-9-10-11-12-13-14	13
Extensions	236 1/4 50-100	2
Universal joint	241 1/4	1
T-handle with sliding square drive	240 1/4	1
Spinner with handle	243 1/4	1
Reversible ratchet with sealed mechanism (certified IP51)	237 A 1/4	1



YouTube



**38**  
PIECES

**1 1/4"**



900 g | 155 mm | 95

**609 1/4" EB**   
**U06090002**

**Assortment with hexagonal sockets and bits in bimaterial box**

- Compact bimaterial box with soft-touch covering

DESCRIPTION	ITEM/SIZE	PCS.
Hexagonal sockets	235 1/4" EN 5,5-6-7-8-9-10-11-12-13-14 mm	10
Extensions	236 1/4" 50-100	2
Reversible ratchet with sealed mechanism	237 B 1/4"	1
Universal joint	241 1/4"	1
Spinner with handle	243 1/4"	1
Bits for slot-head screws -1/4"	660 0,6x4,5-1x5,5-1,2x6,5	3
Bits for PHILLIPS® screws -1/4"	660 PH 1-2-3	3
Bits for POZIDRIV® - SUPADRIV® screws -1/4"	660 PZ 1-2-3	3
Bits for hex socket screws -1/4"	660 E 2-3-4-5-6	5
Bits for TORX® Tamper Resistant screws -1/4"	660 STX T10-T15-T20-T25-T27-T30-T40	7
Socket-holder bit -1/4"	660 Q 1/4"	1
Bit-holder sockets	684 1/4"-1/4"	1

## REVERSIBLE RATCHET WITH REVOLVING HANDLE

**1 1/4"**

**237 1/4" AK**  
**U02370003**

Reversible ratchet with revolving handle



**1 1/2"**

**237 1/2" AK**  
**U02370009**

Reversible ratchet with revolving handle



**17**  
PIECES

**3 1/4"**



**612 3/4" EB**   
**U06120017**

13 kg | 425 mm | 83 | 395

**Assortment in sheet steel box with hexagonal sockets**

DESCRIPTION	ITEM/SIZE	PCS.
Hexagonal sockets	235 3/4 N 22-23-24-26-27-28-30-32-36-38-41-46-50	13
Extensions	236 3/4 200-400	2
T-handle with sliding square drive	240 3/4 N	1
Reversible ratchet with sealed mechanism	237 B 3/4	1

**612 3/4" B**   
**U06120016**

**BIHEXAGONAL SOCKETS**

**Assortment in sheet steel box with bihexagonal sockets**

# Ratchets and sockets



YouTube



## MINI TIGHTENING RANGE

Compact dimension.  
Top performance.

Socket-holder

**31**  
PIECES

1/4"

180°

350 g | mm | 120 / 30 / 60

### 606 1/4" SK U06060012

Assortment with bits and reversible ratchet

DESCRIPTION	ITEM/SIZE	PCS.
Reversible ratchet	237 1/4" SFK	1
Bits for slot-head screws -1/4"	660 0,5x4-1x5,5	2
Bits for hex socket screws -1/4"	660 E 1,5-2-2,5-3-4-5-6-7-8	9
Bits for PHILLIPS® screws -1/4"	660 PH 1-2-3	3
Bits for POZIDRIV® - SUPADRIV® screws -1/4"	660 PZ 1-2-3	3
Socket-holder bit - 1/4"	660 Q 1/4"	1
Bits for TORX® Tamper Resistant screws -1/4"	660 STX T10-T15-T20-T25-T27-T30-T40	7
Bits for TORX® screws -1/4"	660 TX T6-T7-T8-T9	4
Magnetic bit-holder adapter - 1/4"	672 1/4" MG 100	1

### 610 1/4" EFK U06100001

Assortment with short hexagonal sockets and reversible ratchet in bimaterial box



YouTube

11 mm

**11**  
PIECES

1/4"

265 g | mm | 120 / 30 / 60

5,5-6-7-8-9-10-11-12-13-14 mm

#### SHORT HEXAGONAL SOCKETS

They offer more accessibility also using a standard ratchet.



1/4"

### 237 1/4" SK U02370062

Reversible ratchet with extension

- 180° swivel head
- Inversion system with integrated lever
- Ratchet mode: maximum accessibility with the compact head and adjustable hinge
- T-handle wrench mode: the extension (L 100 mm) becomes a crossbar and the ratchet can be used as a T-handle bit-holder



## 454

### Outside pullers with two jaws

CODE	A	B	POWER	Ø
U04540000	65 mm	70 mm	1,5 t	13 mm
U04540010	90 mm	110 mm	3 t	17 mm
U04540020	130 mm	110 mm	3 t	17 mm
U04540030	175 mm	165 mm	4 t	17 mm
U04540040	220 mm	165 mm	4 t	17 mm
U04540050	270 mm	220 mm	5 t	21 mm
U04540060	340 mm	220 mm	5 t	21 mm

### COMPLETE KIT FOR DAMAGED SCREWS AND NUTS

20  
PIECES

↔ 210  
↑ 60  
mm ↗ 130



## 458 S20

U04580312

### Assortment of grip sockets and bits for damaged hexagonal screws and nuts

DESCRIPTION	ITEM/SIZE	PCS.
Pullers for damaged nuts and screws	458 B 8-10-11-12-13-14-15-16-17-18-19	11
Set of grip bits for damaged hexagonal screws	458 E 2-2,5-3-4-5-6-7-8	8
Bit-holder sockets	684 1/4	1

### INCLUDED IN THE PRICE



4  
PIECES

## 451 N/S4

U04510100

### Outside puller with three jaws

- Model with self-locking jaws
- Safety pin
- Working screw with 18 mm hexagonal drive
- Possibility of using with two jaws
- Carbon steel pressure screw
- Chrome Vanadium steel body
- Chrome plated and burnished finish
- Working screw M16x2
- Spare safety pins: U.306- 24J3

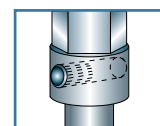

Safety pin increases working safety and preserves tool quality

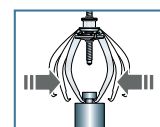

Self-locking self-centring

6  
PIECES

Ø 1÷6 mm



230 g | ↔ 140  
mm | ↑ 47  
↗ 133



## 458 S6

U04580012

### Set of 6 conical extractors

- 458 1-2-3-4-5-6
- For removing broken stud bolts without surface to grip



### HELICOIDAL PROFILE FOR HEXAGONAL NUTS AND SCREWS

The conical helical sockets guarantee an effective external grip on damaged hexagons.

## CLICK TORQUE BAR 811 LB PERFECT MATCH OF ACCURACY AND RESISTANCE

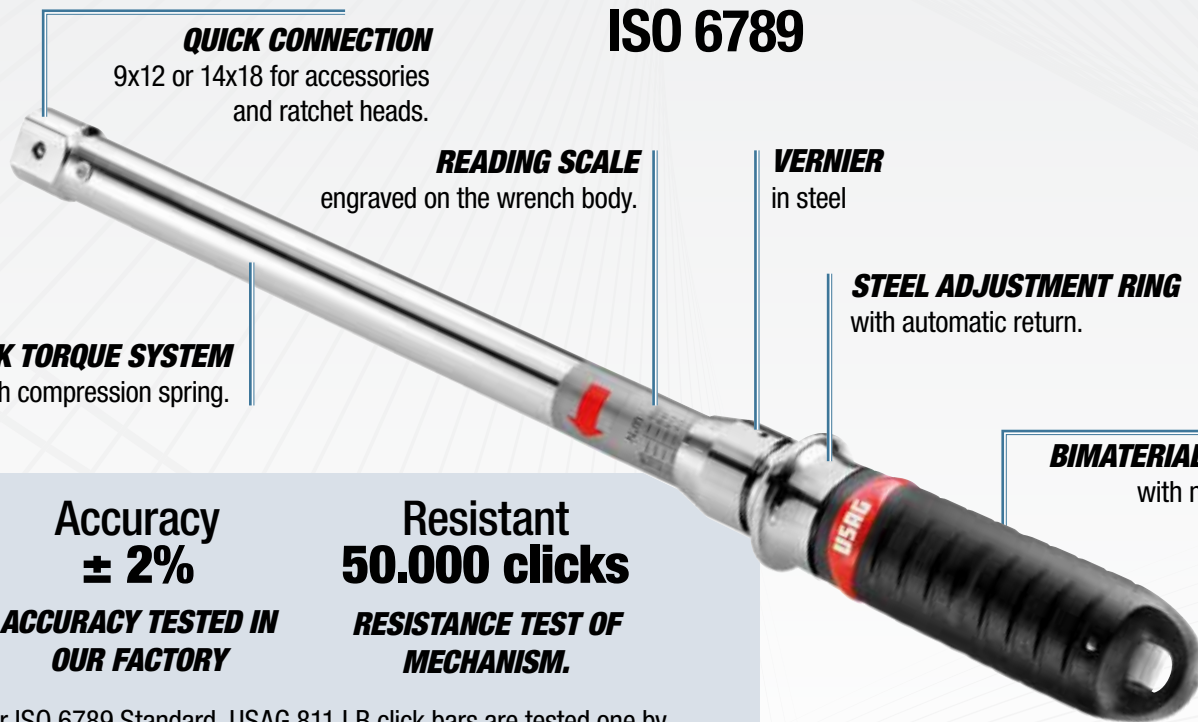

**ISO 6789**

**QUICK CONNECTION**

9x12 or 14x18 for accessories and ratchet heads.

**READING SCALE**

engraved on the wrench body.

**VERNIER**

in steel

**STEEL ADJUSTMENT RING**

with automatic return.

**CLICK TORQUE SYSTEM**

with compression spring.

**BIMATERIAL HANDLE**

with no-slip grip.

**Accuracy  
± 2%**

**ACCURACY TESTED IN  
OUR FACTORY**

**Resistant  
50.000 clicks**

**RESISTANCE TEST OF  
MECHANISM.**

As per ISO 6789 Standard, USAG 811 LB click bars are tested one by one in production, before being packaged. These bars can keep an accuracy between ±2% and ±4%, even after 5,000 tightenings.



YouTube



**ACCURACY  
±2%**

**811 LB**

**Click torque bar**

ITEM	CODE	CAPACITY	□	L	RESOL.
811 LB 50	<b>U08115021</b>	10÷50 Nm	9x12 mm	357 mm	1 Nm
811 LB 100	<b>U08115023</b>	20÷100 Nm	9x12 mm	437 mm	1 Nm
811 LB 200	<b>U08115024</b>	40÷200 Nm	14x18 mm	515 mm	1 Nm
811 LB 350	<b>U08115025</b>	70÷350 Nm	14x18 mm	725 mm	2 Nm

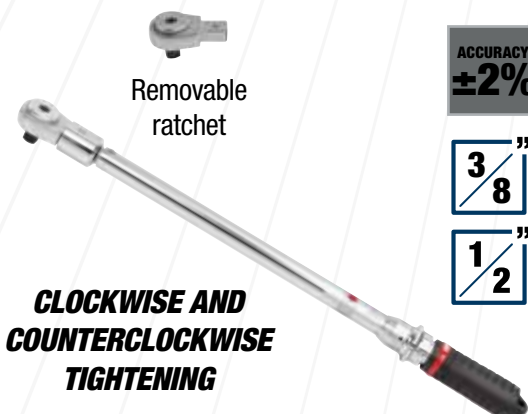

Removable ratchet

**ACCURACY  
±2%**

**811 LBE**

**Click torque wrench with removable ratchet**

ITEM	CODE	CAPACITY	□	□	L	RESOL.
811 LBE 50	<b>U08115026</b>	10÷50 Nm	3/8"	9x12 mm	407 mm	1 Nm
811 LBE 100B	<b>U08115027</b>	20÷100 Nm	3/8"	9x12 mm	487 mm	1 Nm
811 LBE 100C	<b>U08115028</b>	20÷100 Nm	1/2"	9x12 mm	487 mm	1 Nm
811 LBE 200	<b>U08115029</b>	40÷200 Nm	1/2"	14x18 mm	565 mm	1 Nm
811 LBE 350	<b>U08115032</b>	70÷350 Nm	1/2"	14x18 mm	775 mm	2 Nm

## TORQUE WRENCHES 810 SA - 811 SA WITH DIRECT READ SYSTEM.

**REVERSIBLE RATCHET**  
with 72 theet mechanism.

**ISO 6789**

**CLICK TORQUE SYSTEM**  
with compression spring.

**CONICAL HANDLE**  
in anti-slip bimaterial.

**DIRECT READ**  
the value of the torque to apply is quickly visible.

**QUICK TO ADJUST**  
you can set-up faster the torque needed.



### 810 SA

**Direct read torque wrench with reversible ratchet**

- Calibration certificate and REACH (SVHC) declaration included

ITEM	CODE	CAPACITY	☑	L (mm)	RESOL.
810 SA 50	<b>U08105002</b>	10÷50 Nm	3/8"	350	0,25
810 SA 100	<b>U08105003</b>	20÷100 Nm	1/2"	410	0,5
810 SA 200	<b>U08105005</b>	40÷200 Nm	1/2"	475	1,0
810 SA 340	<b>U08105006</b>	60÷340 Nm	1/2"	630	1,0

### 811 SE

**Direct read torque wrench with removable ratchet**

- Calibration certificate and REACH (SVHC) declaration included

ITEM	CODE	CAPACITY	☑	☐	L (mm)	RESOL.
811 SE 50	<b>U08115012</b>	10÷50 Nm	3/8"	9x12	370	0,25
811 SE 100B	<b>U08115013</b>	20÷100 Nm	3/8"	9x12	430	0,5
811 SE 100C	<b>U08115015</b>	20÷100 Nm	1/2"	9x12	430	0,5
811 SE 200	<b>U08115017</b>	40÷200 Nm	1/2"	14x18	510	1,0
811 SE 340	<b>U08115018</b>	60÷340 Nm	1/2"	14x18	665	1,0

ACCURACY  
**±4%**

**3/8"**

**1/2"**

ACCURACY  
**±4%**

**3/8"**

**1/2"**

**CLOCKWISE  
TIGHTENING**



**CLOCKWISE AND  
COUNTERCLOCKWISE  
TIGHTENING**

# Controlled tightening

**CLOCKWISE  
TIGHTENING**



ACCURACY  
**±4%**

**1/4"**

**CLOCKWISE AND  
COUNTERCLOCKWISE  
TIGHTENING**



Removable  
ratchet

ACCURACY  
**±4%**

**1/4"**

**CLOCKWISE AND  
COUNTERCLOCKWISE  
TIGHTENING**



ACCURACY  
**±4%**

**3/4"**

  
**1/4**

ACCURACY  
**±6%**



## 810 N

## ISO 6789

### Torque wrenches with reversible ratchet

- Sensible and audible alarm on reaching preset torque value
- Automatic resetting on pressure release after disengagement
- Supplied with test certificate

ITEM	CODE	CAPACITY	□	L	RESOL.
810 N 5	<b>U08104000</b>	1÷5 Nm	1/4"	197 mm	0,05
810 N 25	<b>U08104001</b>	5 ÷ 25 Nm	1/4"	290 mm	0,05

## 811 NE

## ISO 6789

### Torque wrenches with removable reversible ratchet

- Adjustable torque model for use in combination with fittings from the 811-series
- Sensible and audible alarm on reaching preset torque value
- Automatic resetting on pressure release after disengagement
- Supplied with test certificate

ITEM	CODE	CAPACITY	□	○	L	RESOL.
811 NE 5	<b>U08114009</b>	1÷5 Nm	1/4"	9x12 mm	185 mm	0,05
811 NE 25	<b>U08114010</b>	5÷25 Nm	1/4"	9x12 mm	300 mm	0,05

## 812 N

## ISO 6789

### Torque wrenches with reversible ratchet

- Adjustable torque model for clockwise and counterclockwise tightening by turning the ratchet 180°
- Accuracy ± 4% of the preset torque value
- Readings in Nm
- Sensible and audible alarm on reaching preset torque value
- Automatic resetting on pressure release after disengagement
- Safety block after setting torque
- Supplied in sheet steel box with test certificate

ITEM	CODE	CAPACITY	□	○
812 N 600	<b>U08120006</b>	120 ÷ 600 Nm	3/4"	14x18 mm
812 N 1000	<b>U08120010</b>	200 ÷ 1000 Nm	3/4"	-

## 824 A

## ISO 6789

### Torque screwdrivers

- Adjustable torque model for clockwise tightening, for use in combination with bits from the 660 series or, using an adapter, with sockets from the 1/4" manual series
- Accuracy ± 6% of the preset torque value
- Readings in Nm
- Automatic disengagement on reaching the preset torque value
- Automatic resetting after 120°
- Supplied with regulation key and test certificate

CODE	CAPACITY	L	RESOL.
<b>U08240004</b>	0,5÷2,5 Nm	145 mm	0,1
<b>U08240006</b>	2÷10 Nm	167 mm	0,5



## SCISSORS 207 E STEEL STRENGTH.



YouTube



**THE ONLY ONE WITH INTEGRAL  
STAINLESS STEEL STRUCTURE**

Flexural strength 180 Kg.

**BUILT-IN WIRE  
STRIPPER**



1. Stripping
2. Crimping

**CABLE CUTTER ON  
BOTH BLADES**



Suitable for  
multi-core cables.

**MICRO ANTI-SLIP  
TOOTHING**



**207 E**  
U02070006

Professional scissors for electricians



## SCISSORS 207 D THE REFERENCE FOR ELECTRICIANS.



**HANDLES RESISTANT  
TO FLEXURAL  
STRENGTH UP TO 80 KG**  
glass-reinforced technopolymer.

50 mm<sup>2</sup>

**FLUID AND STRONG BLADES**  
with micro tothing and cable cutter.



**OVERSIZED  
HOLES**

**207 D**  
U02070008

Scissors for electricians,  
stainless steel blades



YouTube

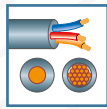

0,02÷10 mm<sup>2</sup>



**146 A**  
U01460003

### Automatic wire strippers, straight

- Cutting and stripping functions for electrical wires
- Capacity 0,02-10 mm<sup>2</sup>/AWG 34-80
- Interchangeable jaws without tools
- Built-in wire cutter
- Precise adjustment of the stripping diameter to avoid damages
- Adjustable stripping length
- After each stripping operation, the jaw opens automatically to facilitate the extraction of the wire
- Ergonomic bimaterial handles



0,5÷1-1,5-2,5-4-6 mm<sup>2</sup>

**753 A**  
U07530003

### Crimping pliers for cable tip terminals

- Rack-type model for reducing the compression effort
- Ergonomic PVC grip which facilitates one-handed tightening
- Stainless steel mould with 5 shapes
- Sheet steel body



15÷25  
WATT

MAX  
495°C

**063 W**  
U00630002

### Electronic pen-type soldering iron, double power

- Professional soldering iron for tin
- Push-button switch
- Perfect for different applications on electrotechnical field
- Steel tip for long service life
- Housing in plastic material resistant to oils and hydrocarbons
- Power supply 230V
- Supplied with bench holder



2011/65/UE  
2012/19/EC

*Insulated*



*Not-Insulated*

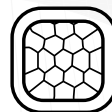

0,14÷10 mm<sup>2</sup>

**753 KA**  
U07530004

### Self-adjusting crimping pliers for square terminals

- For insulated and non-insulated terminals
- Capacity 0,14-10 mm<sup>2</sup>/AWG 26-8
- Opening system for multiple consecutive operations
- Allows to crimp applying little force on the handles
- Low weight and compact size for easy handling

## SMART FUNCTION

Automatically selects AC/DC  
voltage, resistance,  
frequency

MAX  
600 V

RMS



**074 A**  
U00740001

### SMART digital multimeter

- AC/DC measurement
- Resistance and continuity measurements (acoustic sound if circuit resistance is lower than 40 to  $\Omega$ )
- Frequency measurements
- AC/DC current measurement with 076 P ammeter



CAT III 600V

### TECHNICAL CHARACTERISTICS

Direct voltage DC	1÷600 mV÷V
Alternating voltage AC	1÷600 mV÷V
Resistance	0÷10 $\Omega$ ÷M $\Omega$
Frequency	3÷40 kHz
Battery type (supplied)	2xAAA 1,5V



$\varnothing$  4÷28 mm<sup>2</sup>



YouTube

**163**

U01630001

### Multi-purpose cable sheath stripper

- For circular and longitudinal stripping of cables with external sheathing in PVC
- Trigger system (-30% effort): necessary pressure 75N
- Roller for regulating cutting depth
- Self rolling stripping blade
- Trigger stop when blade is out
- Safety blade stop
- Ergonomic plastic body
- Spare blade included
- Kit of spare blades code 872272



**007 MV**  
U00070035

### Tool-holding pouch (empty)

- High strength fabric
- Velcro belt fixing
- Four stretch pockets for tools
- Hook for tape



**007 MLV**  
U00070030

### Tool-holding pouch with belt (empty)

- High strength fabric
- Six stretch pockets for tools
- Hook for tape
- Adjustable belt from 80 to 120 cm



## 305 N

### Swedish model pipe wrenches with straight jaws at 90°

- Chrome Vanadium steel

CODE	CAPACITY	LENGTH
U03050002	1"	40 mm 330 mm
U03050003	1 1/2"	55 mm 420 mm
U03050004	2"	67 mm 540 mm
U03050005	3"	103 mm 690 mm



**COPPER**

## 314 DA

U03140033

∅ 3-35 mm  
∅ 1/8-1 3/8"

### Tube cutter for Copper and light alloy tubes

- Model with telescopic advance mechanism and uniform dimensions
- Four grooved guide-rollers for cutting flanged tubes
- Quick replacement of the wheel, without any tool
- Ergonomic knob



**PLASTICS**



## 317 K

U03170012

∅ 35 mm  
∅ 1 3/8"

### Tube cutters for plastic tubes

- For cutting PEX, PEHD, PVC, PER tubes
- Rack-type model for an effortless progressive cutting action
- Light alloy body
- Enamelled finish



**COPPER**

## 314 C

U03140032

∅ 3-30 mm  
∅ 1/8-1 1/8"

### Tube cutter for Copper and light alloy tubes

- Grooved guide-rollers for cutting flanged tubes.
- Quick replacement of the wheel, without any tool.
- Maximum tube thickness: 2 mm



**PLASTICS**



## 317 AM

U03170001

∅ 22 mm  
∅ 7/8"

### Tube cutter for PEX and plastic tubes

- Blade with special shape and PTFE coating
- Automatic blade return
- Closure system with one hand
- Dimensions: 169x50x19 mm



**995 AF**  
U09950006

### Hand riveter with swivel head

- 360° adjustable head
- Suitable for Aluminum rivets
- 4 interchangeable heads
- Light alloy body
- Plastic handles
- Metal clip for opening lock
- Supplied with head disassembly key



**995 A**  
U09950001

### Hand riveter

- Steel: Ø 2,4 - 3,2 - 4 (3/32 - 1/8 - 5/32)
- Aluminium: Ø 2,4 - 3,2 - 4 - 4,8 mm (3/32 - 1/8 - 5/32 - 3,16")
- Light alloy body
- Pressed sheet steel pressure lever
- Handgrips with spring-action opening
- Supplied with three interchangeable nozzles and service key



**-20%  
EFFORT**

### COMPACT AND POWERFUL

Only 330 mm long  
20% less effort than the standard model



**995 LA**  
U09950004

### Straight compact hand riveter

- Compact model with the same capacity as a standard long riveter
- The internal lever system reduces operator effort
- Suitable for Aluminum and steel rivets
- 5 interchangeable heads
- Removable holder for spent nails
- Light alloy body
- Plastic handles



**995 CA**  
U09950008

### Hand riveter for blind-nut rivets

- Compact model with internal lever system that reduces operator effort
- Supplied with 4 interchangeable heads (M4-M5-M6-M8)
- To be used with aluminium and steel blind nuts (M4-M5-M6-M8) and stainless steel (M4-M5)
- Light alloy body
- Plastic handles
- Supplied in a plastic case (LxDxH: 320x175x50 mm) with blind nuts holders (not included)

## STAINLESS STEEL BLADE

**211 A**  
U02110001

### Multi-purpose scissors

- Blade with micro anti-slip toothing
- Selection lever to adapt to small and big hands
- Security lever to block the blades
- Antislip bimaterial ergonomic handgrips



## STAINLESS STEEL BLADE

**210 C**  
U02100003

### Multi-purpose scissors

- Stainless steel blade with micro antislip toothing
- Big ergonomic bimaterial handless
- Perfect for Aluminium, cardboard, rubber, leather, moquette, etc.

**FOR  
RIGHT-HANDERS**

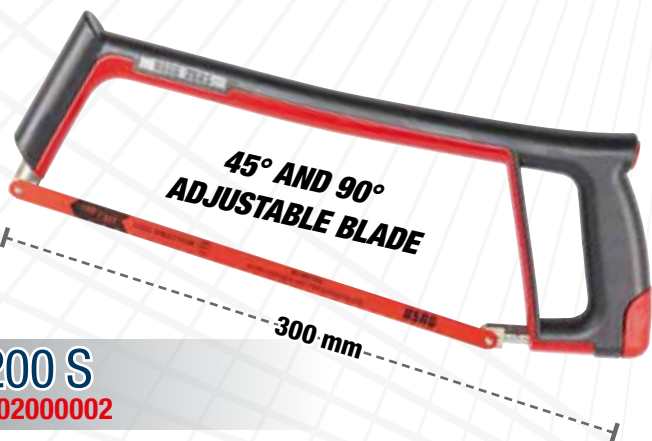

**200 S**  
U02000002

### Hacksaw

- Steel body with anti-slip and shock resistant plastic coating
- Supplied with Cobalt blade 200 C24

**MAX  
CAPACITY:  
2 KG**



**442 TA**  
U04420013

### Telescopic retriever with articulated magnet

- For recovering magnetizable items from inaccessible places
- Articulated head: aluminum
- Shaft material: carbon steel with zinc finishing
- PVC handle

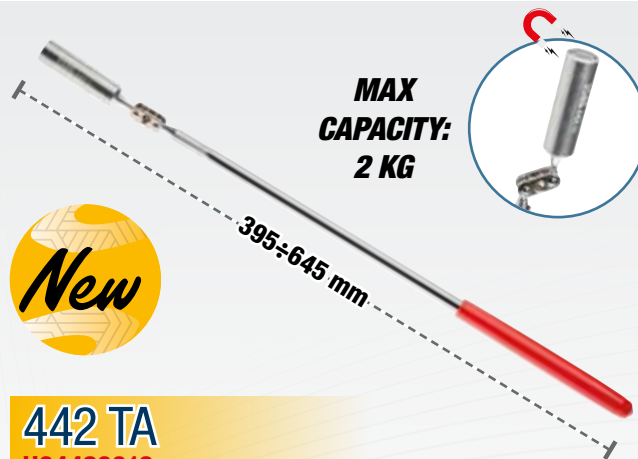

## CENTRAL CUTTER



**196 N**

### Bolt cutters with central cutter

CODE	LENGTH	 2000 N/mm <sup>2</sup> Ø MAX	 1600 N/mm <sup>2</sup> Ø MAX	
U01960002	450 mm	6 mm	7 mm	1,9 Kg
U01960003	600 mm	7 mm	10 mm	3,5 Kg
U01960004	750 mm	9 mm	13 mm	4,5 Kg
U01960005	900 mm	10 mm	16 mm	6,1 Kg
U01960006	1050 mm	11 mm	18 mm	8,3 Kg

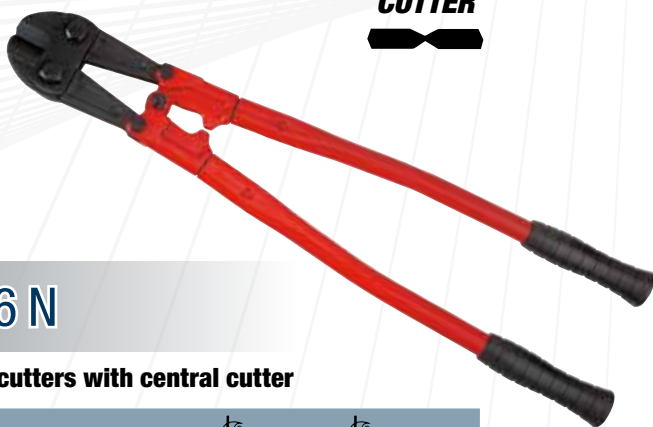

## SEMI-FLUSH CUTTER



**196 NR**  
U01960001

### Bolt cutters with semi-flush cutter

- Blades with high-resistance cutting edges
- Handgrips in PVC

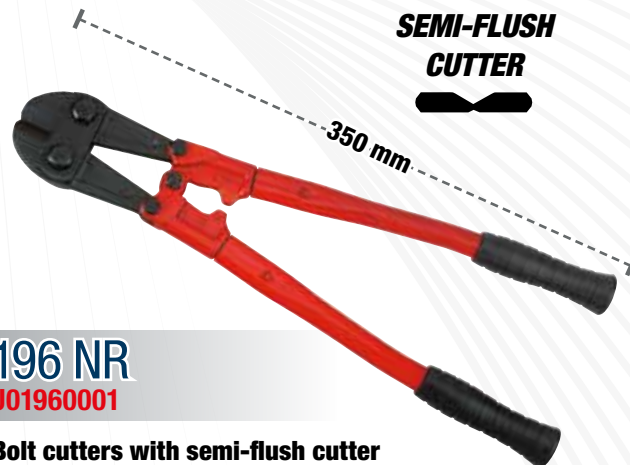

2-3-4-5-6-8 mm

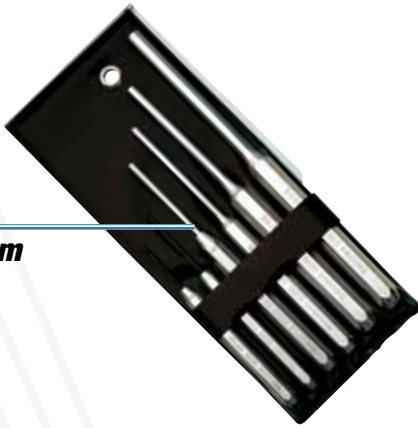

6  
PIECES

## 367 SE6

U03670081

### Set of 6 pin punches

- 367/2x115-3x125-4x145-5x165-6x180-8x200 mm
- Supplied in plastic pouch
- Chrome Vanadium steel
- Inserted phosphatised tips for the 2 and 3 mm sizes

## UNI 7784

376

### Mallets

- Model with interchangeable plastic tips
- Carbon steel body
- Ash wood handle

CODE	Ø TIP	LENGTH
U03760001	22 mm	250 mm
U03760002	28 mm	275 mm
U03760003	35 mm	300 mm
U03760004	42 mm	325 mm
U03760005	50 mm	350 mm
U03760006	60 mm	380 mm

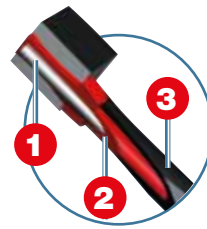

### COMBINED MATERIALS FOR EXCELLENT RESULTS

- 1 Graphite core: maximum flexural strength.
- 2 High quality: Polypropylene body to absorb vibrations.
- 3 Rubber coating resistant to hydrocarbons.

## DIN 1041



382 F

### Hammers for mechanics with graphite handle

- German model with flat square surface and symmetric peen
- Graphite handle

CODE	HEAD	LENGTH
U03820102	200 g	285 mm
U03820103	300 g	300 mm
U03820105	500 g	310 mm
U03820107	800 g	350 mm
U03820108	1000 g	355 mm

Head in Carbon steel forged and subjected to differentiated heat treatment to guarantee a longer life and avoid chipping or upsetting of the striking surface.

## UNI 7777 DIN 6475

382

### Hammers for mechanics

- German model with flat square head and symmetric peen
- Ash wood handle



CODE	HEAD	LENGTH
U03820002	100 g	260 mm
U03820004	200 g	280 mm
U03820006	300 g	300 mm
U03820007	400 g	310 mm
U03820008	500 g	320 mm
U03820009	600 g	330 mm
U03820010	800 g	350 mm
U03820011	1000 g	360 mm
U03820013	1500 g	380 mm
U03820014	2000 g	400 mm

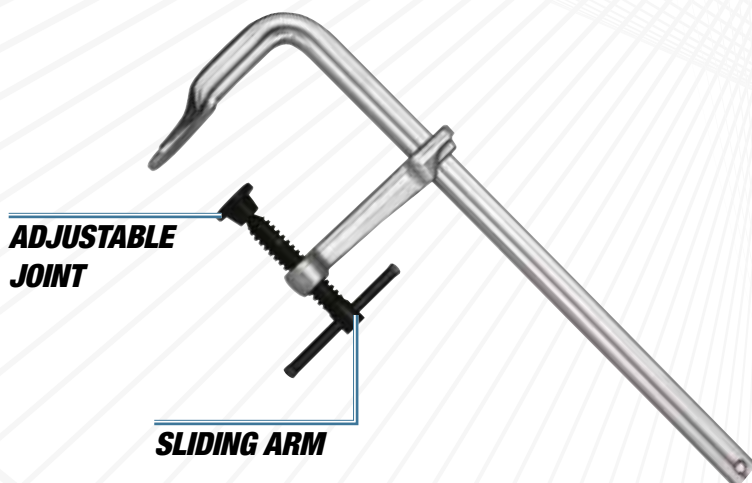

## 997 A

### Screw-type clamp

- Body and sliding arm in forged steel

CODE	OPENING	SECTION	
<b>U09970002</b>	160 mm	16x7,5 mm	0,5 kg
<b>U09970003</b>	200 mm	19,5x9,5 mm	0,9 kg
<b>U09970004</b>	250 mm	22x10,5 mm	1,2 kg
<b>U09970005</b>	300 mm	25x12 mm	1,8 kg
<b>U09970006</b>	400 mm	25x12 mm	1,9 kg
<b>U09970007</b>	500 mm	25x12 mm	2,1 kg
<b>U09970008</b>	600 mm	25x12 mm	2,3 kg
<b>U09970009</b>	800 mm	27x13 mm	3,3 kg
<b>U09970010</b>	1000 mm	27x13 mm	3,7 kg

## 997 B

### Lever-type clamp

- Quick lever model with precise regulation
- Body and sliding arm in forged steel
- Adjustable pressure cap

CODE	OPENING	SECTION	
<b>U09970013</b>	120 mm	13,5x6,5 mm	0,7 kg
<b>U09970014</b>	160 mm	16x7,5 mm	1 kg
<b>U09970015</b>	200 mm	19,5x9,5 mm	1,3 kg
<b>U09970016</b>	250 mm	22x10,5 mm	1,9 kg
<b>U09970017</b>	300 mm	25x12 mm	2,7 kg
<b>U09970018</b>	400 mm	25x12 mm	2,8 kg
<b>U09970019</b>	500 mm	25x12 mm	3 kg

**ADJUSTABLE PRESSURE SURFACE**

**LEVER WITH INTEGRATED RELEASE BUTTON**



**10**  
PIECES

### FOR RINGS WITH CAPACITY DIAMETERS FROM 20 TO 100 MM

Rings with holes on top



Rings with carvings on top

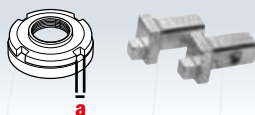

## 282 S10

**U02820200**

2 kg | 330 mm | 215

### Assortment in ABS case with pin wrenches for round and square ring nuts

- For rings with holes bored on the face
- The wrench is adjustable by turning the centre screw
- Removable pins
- Capacity: 20 to 100 mm
- Satin chrome finish
- High resistance ABS case with quick closing system
- Empty inner foam module: code U05191054Q

DESCRIPTION	SIZE	PCS.
Round pins	<b>(d)</b> 2,5 - 3 - 4 - 5 - 6 - 7 - 8 - 9 mm	4
Square pins	<b>(a)</b> 4 - 5 - 6 - 8 mm	4



## DIN 338

HSS-G

14  
PIECES



### 988 LA/S14

U09880070

**Assortment with tap and drills**

- Ø drills: 2,5-3,3-4,2-5,0-6,8-8,5-10,2
- M taps: 3x0,5-4x0,7-5x0,8-6x1-8x1,25-10x1,5-12x1,75

## DIN 338

HSS-G

19  
PIECES



### 988 MA/S19

U09880073

**Assortment with drills**

- Ø drills: 1,0-1,5-2,0-2,5-3,0-3,5-4,0-4,5-5,0-5,5-6,0-6,5-7,0-7,5-8,0-8,5-9,0-9,5-10,0

## DIN 338

HSS-G

25  
PIECES



### 988 MA/S25

U09880074

**Assortment with drills**

- Ø drills: 1,0-1,5-2,0-2,5-3,0-3,5-4,0-4,5-5,0-5,5-6,0-6,5-7,0-7,5-8,0-8,5-9,0-9,5-10,0-10,5-11,0-11,5-12,0-12,5-13,0



HSS

3  
PIECES



### 988 D/S3

U09880020

**Set in sheet steel case**

ITEM	Ø STEPS	Ø SHAFT	LENGTH
988 D1	4-5-6-7-8-9-10-11-12 mm	6 mm	65 mm
988 D2	4-6-8-10-12-14-16-18-20 mm	8 mm	75 mm
988 D3	4-6-8-10-12-14-16-18-20-22-24-26-28-30 mm	10 mm	100 mm

HSS

12  
PIECES



### 988 G/S12

U09880100

**Set of 10 bimetallic hole saws**

- 10 pcs 988 G (Ø 19-22-25-29-35-38-44-51-57-64)
- Cutting depth Max 38 mm

HSS

10  
PIECES



Ø 6 mm



### 988 E/S10

U09880062

**Set of ten rotary burrs in hard metal**

- 8 pcs. (Ø 10 and 12 shapes EA-EC-EF-EG)
- 2 pcs (Ø 12 shapes ED-EM)

# Lighting



YouTube



Adjustable hooks



SMD LED



COB LED



1 = 18 h  
2 = 3,6 h  
3 = 1,8 h



Li-ion

**RECHARGEABLE**



USB-C

**889 RL**

U08890036

LED inspection lamp

**DUAL USE**



45 LUMEN

**LAMP**



MAX 420 LUMEN

**TORCH**

2 brightness levels (120 and 420 lumen)



YouTube



Magnetic base and hook clamp



SMD LED



COB LED



1 = 3 h  
2 = 10 h  
3 = 35 h



Li-ion

**RECHARGEABLE**



USB-C

**889 IL**

U08890046

Articulated LED inspection lamp

**TRIPLE FUNCTION**



50 LUMEN

**HEAD**



400 LUMEN

**TORCH**



150 LUMEN

**FRONTAL**



YouTube



**MOTION DETECTION SENSOR**



SMD LED



IP54



1 = 18 h  
2 = 3,6 h  
3 = 1,8 h



Li-ion

**RECHARGEABLE**



USB-C

**889 GR**

U08890044

LED compact spotlight

**3 BRIGHTNESS LEVELS**



MAX 500 LUMEN

50, 250 and 500 lumen with a simple touch

**New**



**Only 94 mm length**



COB LED



IP20



1 = 1,5 h  
2 = 3 h  
3 = 3h



Li-ion

**889 SP**  
U08890055

LED pocket pen lamp



YouTube

**DUAL USE**



Frontal



Torch

Magnetic hook that can be rotated 360°

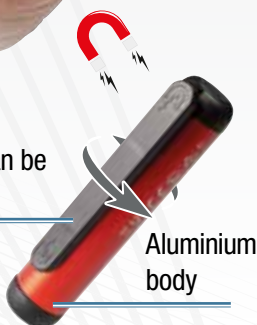

Aluminium body

**RECHARGEABLE**



USB-C



Lamp  
COB LED



Torch  
SMD LED



IP20



Li-ion

**889 RP**  
U08890045

Compact LED rechargeable inspection lamp



YouTube

**DUAL USE**



Lamp



Torch

**360°**

**180°**



131 mm



USB-A



COB  
LED



IP67



2,5 h



1 = 8 h  
2 = 4 h  
3 = 2,5 h



IK07



Li-ion

**889 RT**  
U08890038

Rechargeable LED spotlight - certified IP67



YouTube

**3 BRIGHTNESS LEVELS**



**MAX  
1500  
LUMEN**

500, 1000 and 1500 lumen with a simple touch



**WORKS WITHOR WITHOUT CABLE**

5 meters cable included

## INTEGRATED TRANSFORMER

No external power supply.



YouTube

12 V 1200 A

10 kg 400 mm 320 115



## 1613 RA12

U16130019

Professional start booster 12 V, portable

- Shockproof ABS shell
- Also suitable for sealed batteries

3500 A

Cable length  
155 cm

## REAR CONNECTOR FOR VOLTAGE SELECTION



12 V 1400 A  
24 V 700 A

20,8 kg 560 mm 200 590



12V - 3700 A

## 1613 AGM12-24

U16130013

Professional start booster 12-24 V, portable

- Shockproof ABS shell
- Overvoltage protection

24V - 1860 A

Cable length  
155 cm



YouTube

## COMPRESSION POWER

735 kg (6 bar), 1226 kg (10 bar).

## 447 T

U04470101

Universal pneumatic shock absorber dismantler

- Ideal for cars
- Supplied with lower brackets 447 TC1 (78÷130 mm) and 447 TC2 (105÷182 mm), vice 447 TA and universal upper clamps 447 TB1

### TECHNICAL CHARACTERISTICS

Compression power	735 kg (6 bar) - 1226 kg (10 bar)
Recommended air pressure	6÷10 bar
Piston stroke	420 mm
Cylinder	Aluminium alloy and nylon resin

60 kg 470 mm 1.390 450



## Adjustable pressure up to 4 BAR

12 V 10 Litres

## 2847/3

U28470084

Brake bleeder

- For changing, filling and bleeding the circuit of brakes on cars and industrial vehicles
- Device designed exclusively for brake fluids DOT 3, DOT 4, DOT 5.1. No LHM.

### TECHNICAL CHARACTERISTICS

Operating liquid system	Peristaltic pump (no direct/liquid contact, no air pressure on liquid)
Power supply	12 V (alligators clips)
Tank capacity	10 liters
Pressure limiting device	4 bar
Elastic spiral hose	4 m (elastic)
Power cable	4 m



Supplied with:

- spare gaskets
- 1 multi-diameter cap 44-45-46 mm (2847 N11)
- 1 tank for oil recovery.

## FOR 6÷12 V BATTERIES

Also for  
Start & Stop



**890 K**  
U08901000

Digital battery tester with printer



YouTube



Compatible with  
thermocouple K



**1651**  
U16510001

Digital infrared thermometer



**IDEAL TO DROP OIL INTO  
THE CAR DIFFERENTIAL**

**Not suitable for fuels and  
mineral oils**

**1,5**  
Litres



**421 P**  
U04210020

Suction gun

**IDEAL FOR SUCTION AND DISPENSING OF  
OIL, ANTIFREEZE, POWER STEERING OIL**



**421 M**  
U04210021

Suction gun

**3**  
Litres

**IDEAL TO DROP  
OIL INTO THE CAR  
DIFFERENTIAL**

Working  
pressure  
6÷10 bar



**2847 A**  
U28470086

Vacuum brake bleeder

**9,5**  
Litres



4,1 kg | 230 mm | 627 | 302



**1785 B**  
U17850005

Fluid extractor

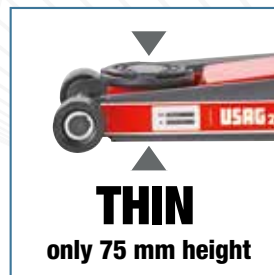

**3**  
TON

**30,5**  
kg



**3t**



## 2550 A

U25500001

### Hydraulic service jack 3t for cars and commercial vehicles

- Steel structure
- High capacity for use on cars, SUVs and vans
- Dual pump system to lift the car faster
- Equipped with manual descent control
- Air bleed valve, to avoid risk of over-load

## 2550 B

U25500002

### Hydraulic service jack 2t

- Steel structure
- Versatile and compact for use in narrow spaces
- Dual pump system to lift the car faster
- Equipped with lifting pedal
- Equipped with manual descent control
- Air bleed valve, to avoid risk of over-load



**2**  
TON

**32,5**  
kg



**2t**



**2**  
PIECES

## 1950 C

### Pair of jack stands

- Adjustable height with toothed mechanism and lever release
- Locking pin with chain
- 1950 C/3: model adjustable in 10 positions
- 1950 C/6: model adjustable in 13 positions



## 2000 A

U20000100

### Inspection creeper

- Headrest in vinyl resistant to hydrocarbons, padded with high resistance foam rubber
- Plastic body resistant to hydrocarbons, washable



CODE	CAPACITY	H MAX	H MIN	DIMENSIONS	W
U19501001	3 t	427 mm	300 mm	207x188 mm	7 kg
U19501002	6 t	620 mm	400 mm	285x250 mm	14 kg



**3**  
PIECES

**1 1/2"**

**270 C/C3**  
U02700106

Assortment with hexagonal impact sockets for tyre rims with teflon protection in modular box

↔ 190  
↑ 58  
mm ↙ 144

**POSSIBILITY TO STORE  
IT INSIDE OUR ROLLER  
CABINET DRAWERS**

Carrying handle

230 g | 475 mm  
50 mm | 290 mm

**2000 G**  
U20000110

Kneeling pad



YouTube  
**VIDEO  
TUTORIAL**



**10**  
PIECES

**272 DS**  
U02720001

**Kit to extract nuts and screws from alloy wheels**

- Does not damage the alloy rim
- Special tungsten carbide drills capable of drilling any type of material (lubricate with cutting oil at each use)
- Super thin conical sockets to center/extract on any type of alloy wheel



## Manual use on the wheel nuts

**3**  
PIECES

**1 1/2"**

**XGRIP**

**235 1 1/2" XL/C3**  
U02354100

Assortment with long hexagonal sockets X-Grip in modular box (3 pcs.)



**17**

**19**

**21**

**X-GRIP BENEFITS:**

- Perfect grip on new or damaged hexagons, up to 80%
- It transmits more torque than a standard socket.
- No damage to new hexagons

**XGRIP**



**Discover the  
features,  
go to page 4**

## FAST OIL-FILTER WRENCH 443 N AUTOMATIC BELT CLAMPING.

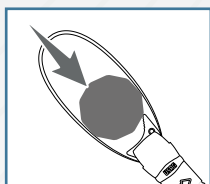

**AUTOMATIC  
BELT CLAMPING**

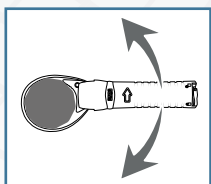

**RATCHET EFFECT**

Working rapidly. Possibility to work in narrow spaces.

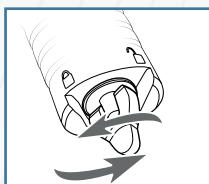

**LEVER TO INCREASE  
CLAMPING POWER**



**443 N**  
**U04430005**

**Fast oil-filter wrench  
(cars)**



**66÷105  
mm**



**6  
PIECES**

**3  
8"**



Allows the re-tightening at the original torque (value indicated on the plastic cap)

**446 DA/SE6**  
**U04461104**

**Set of 6 cup wrenches for oil filters**

- 3/8" square drive
- Steel body
- Set for Fiat, Lancia, Alfa Romeo, BMW, Renault, Volkswagen, Skoda, Audi, Seat, Mercedes
- Profile dimensions: Ø 74 mm x 14 sides - Ø 75 mm x 16 sides - Ø 86 mm x 16 sides - Ø 102 mm x 14 sides - Ø 66 mm x 18 sides - Ø 96 mm x 18 sides



Frame the QR code and download the list of applications or go to [usag-tools.net](http://usag-tools.net)

**3  
8"**

**1  
2"**

**30  
PIECES**

**446 S28**  
**U04461204**

**Set of 30 oil-filter cap wrenches**

- Sizes of the oil-filter cap wrenches (Ø x N ° sides): 66/6 - 65/14 - 65/67 - 68/14 - 73/14 - 74/15 - 74/76 - 75/77 - 76/12 - 76/14 - 76/30 - 76/8 - 78/15 - 80/15 - 80/82 - 86/16 - 86/18 - 90/15 - 92/10 - 93/15 - 93/36 - 93/45 - 95/15 - 96/18 - 100/15 - 106/15 - 108/15 - 108/18

7 kg | 620 mm | 70 mm | 500 mm



Frame the QR code and download the list of applications or go to usag-tools.net



**IN ALLUMINIO**

**446 DT/S2**

**U04461203**

**Set of two cap wrenches for oil filter covers - Japanese cars**

- Reduces the risk of damage to the oil filter covers
- Can also be used for tightening with a torque wrench



**2**  
PIECES

Frame the QR code and download the list of applications or go to usag-tools.net



**263/S16**

**U02631400**

**Oil draining kit**

- Magnetic sockets to hold plugs
- 1 hinged wrench 3/8"
- 2 bits  $\odot$  8-10 mm 3/8"
- 6 bits  $\odot$  8-10-12-13-14-17 mm 3/8"
- 6 hexagonal sockets  $\bullet$  13-14-17-18-19-21 mm 3/8"
- 1 TORX® bit  $\odot$  T45

Connection for oil collector

**16**  
PIECES

**3/8**"



Integrated oil collection tray

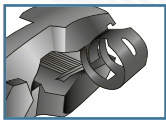

**2 in 1**

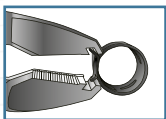

**871 D**

**U08710001**



**Pliers for CORBIN clamps**

- Model with frontal or side hooking
- Jaws with serrated gripping surface



**870 C**

**U08700006**

**Pliers for fuel hoses**

- For petrol and diesel vehicles
- Ergonomic bimaterial handgrip

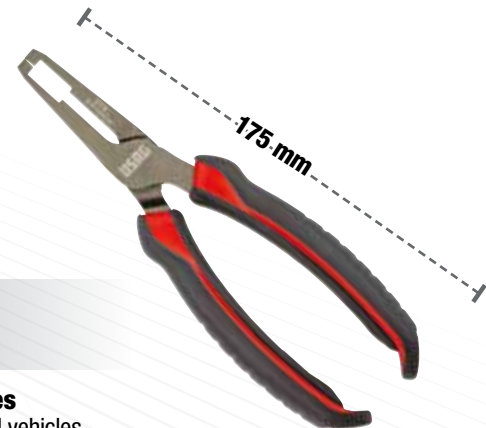

3 working positions



**871 C**

**U08719005P**

**CLICK spring-clips pliers**

- Three-axial heads to work in any position
- To open and close CLICK spring-clips on fuel circuits, intake manifolds and hydraulic circuits



**22**  
PIECES

**1881 S22**

**U18810082**

**Set of 22 wrenches for assembling and disassembling the nuts of alternators pulleys**

- Supplied in a plastic case





### 2 MODES:

- 1 250 l/min - 50°÷400°C
- 2 500 l/min - 50°÷600°C

MAX  
600°

2000  
WATT

**391**  
U03910001

### Digital heat gun

- Model with electronic checking of temperature and air volume by digital display
- Possibility to set programs: 2 heating modes and 2 air flows selectable
- Equipped with a cooling system

Accessories included

**5**  
PIECES

To extract mouldings, fasteners, trim clips from door panels and dashboards



**426 B/S5**  
U04260006

Set of 5 tools for plastic elements

**4**  
PIECES

To separate timing belt cover, cylinder head engine, drive belt etc.



**426 D/S4**  
U04260005

Set of 4 plastic separator scrapers



### TECHNICAL CHARACTERISTICS

Suction cup threaded connection	M18
Sound level	78 Db
Total length	610 mm
Weight	4 Kg
Recommended air pressure	6,2 bar
Air inlet	1/4"

**400 P**  
U04000010

### Pneumatic dent puller

- Ideal to remove dents without the need to repaint
- Supplied with 3 suction cups (Ø 75-100-125 mm), in a plastic case with transport handle and closure clip
- Spare part kit with 3 suction cups: code 1004735-98

**4**  
PIECES

For removal of counterweights, silicone, mouldings etc.



**426 C/S4**  
U04260007

Set of 4 multi-purpose plastic scrapers

**2**  
PIECES



**115 CL/SE2**  
U01150022

### Double-joint pliers with half-round jaws

- Ideal for gripping pieces and parts difficult to reach

Controlled tightening using ratchets or T-wrenches

1/2"



YouTube

## 814 A

### Torque-angle digital adapter

- Torque and angle tightening with digital precision using conventional tools
- For CW and CCW tightening
- Torque accuracy:  $\pm 4\%$
- Angle accuracy:  $\pm 2\%$
- Measuring mode: peak/track
- Measuring unit: Nm/ft.lb/in.lb/kgcm/degree
- Visible (LED) and audible (BUZZER) indicators when preset target value is reached
- 9 presettable target values
- 50 memory slots for measured values
- Supplied in ABS case with calibration certificates
- Power supply: 2 batteries AAA (included)

CODE	CAPACITY	RESOL.
U08140003	6,8÷135 Nm	1/2" 0,1
U08140004	10÷200 Nm	1/2" 0,1
U08140005	17÷340 Nm	1/2" 0,1

Correct measurement of the angle in any position

PRECISION  
 $\pm 2\%$



YouTube

## 831 A

U08310001

### Digital angle meter

- Correct measurement of the angle in any position
- For CW and CCW tightening
- Accuracy:  $\pm 2\%$
- Range: 0 - 360°
- Resolution: 0,1°
- Visible (LED) and audible (buzzer) indicators when preset target value is reached
- 9 presettable target values
- 50 memory slots for measured values
- Supplied in ABS case with calibration certificates
- Power supply: 2 batteries AAA (included)

9  
PIECES

Two wire brushes  
 $\varnothing 20\text{mm}$  and  $25\text{mm}$



## 885 F

U08850004

### Injector cleaning kit

- Ideal for duct cleaning of injectors mounted on common rail engines

6  
PIECES

1/2"



## 884 C/S6

U08841000

### Set of six wrenches for injector pipes fittings

- For assembly and disassembly of injectors pipes fittings
- Length: 98 mm
- Sizes: 12-14-16-17-18-19 mm

## LED LIGHTING

1/2"

1.898 Nm 2,2 kg



YouTube

## MAGNESIUM ALLOY CASING



# THE TOP OF THE RANGE

943 PC1 1/2"

U09430001

### Magnesium impact wrench with LED - the top

#### TECHNICAL CHARACTERISTICS

Square drive	1/2"	Recommended air pressure	6,2 bar
Bolt capacity	M20	Sound level	94 ±3 dB(A)
Max torque	1.898 Nm	Sound power	105 ±3 dB(A)
Torque in use (Nm min-Max)	320÷460 Nm	Vibrations	6,4 m/s <sup>2</sup>
Strokes per minute	1200	Air inlet	1/4"
Free speed	6.500 rpm	Ø internal hose	10 mm
Average air consumption	172 l/min	Weight	2,2 kg

## MAGNESIUM ALLOY CASING

1/2"

1.600 Nm 2 kg



YouTube



# THE REFERENCE MODEL

929 PC1 1/2"

U09290001

### Magnesium impact wrench

#### TECHNICAL CHARACTERISTICS

Square drive	1/2"	Recommended air pressure	6,2 bar
Bolt capacity	M16	Sound level	93 ±3 dB(A)
Max torque	1.600 Nm	Sound power	104 ±3 dB(A)
Torque in use (Nm min-Max)	280÷440 Nm	Vibrations	6,2 m/s <sup>2</sup>
Strokes per minute	1.300	Air inlet	1/4"
Free speed	7.000 rpm	Ø internal hose	10 mm
Average air consumption	172 l/min	Weight	2,0 kg

# EXTRA-COMPACT



942 PC3 1/2"

U09420012

### Extra-compact impact wrench

#### TECHNICAL CHARACTERISTICS

Square drive	1/2"	Recommended air pressure	6,2 bar
Bolt capacity	M16	Sound level	91,1±3 dB(A)
Max torque	861 Nm	Sound power	108,1±3 dB(A)
Torque in use (Nm min-Max)	150÷220 Nm	Vibrations	9,57 m/s <sup>2</sup>
Strokes per minute	1650	Air inlet	1/4"
Free speed	10.000 rpm	Ø internal hose	10 mm
Average air consumption	127 l/min	Weight	1,3 kg

YouTube



**Modular with the drawers of USAG roller cabinets**



**Modular with the drawers of USAG roller cabinets**



**Modular with the drawers of USAG roller cabinets**

## 943 PC1/C12 U09430005

↔ 415  
↓ 92  
mm ↗ 283

1 1/2"

**Assortment with hexagonal sockets and impact wrench in modular box**

DESCRIPTION	ITEM/SIZE	PCS.
Magnesium impact wrench with LED - the top	943 PC1 1/2	1
Impact hexagonal sockets	235 1/2 M/ 10-13-17-18-19-22-24-27-30-32 mm	10
Lock pins	235 MCA/4-6	2
Safety rings	235 MDA/4-6	2
Impact extensions	236 1/2 M/125	1

12  
PIECES



## 929 PC1/C12 U09290005

↔ 415  
↓ 92  
mm ↗ 283

1 1/2"

**Assortment with hexagonal sockets and impact wrench in modular box**

DESCRIPTION	ITEM/SIZE	PCS.
Magnesium impact wrench	929 PC1 1/2	1
Impact hexagonal sockets	235 1/2 M/ 10-13-17-18-19-22-24-27-30-32 mm	10
Lock pins	235 MCA/4-6	2
Safety rings	235 MDA/4-6	2
Impact extensions	236 1/2 M/125	1

12  
PIECES



## 942 PC3/C7 U09420015

↔ 375  
↓ 80  
mm ↗ 186

1 1/2"

**Assortment with hexagonal sockets and impact wrench in modular box**

DESCRIPTION	ITEM/SIZE	PCS.
Extra-compact impact wrench	942 PC3 1/2	1
Impact hexagonal sockets	235 1/2 M/ 13-17-19-21-22-24 mm	6
Lock pins	235 MCA/4	1
Safety rings	235 MDA/4	1

7  
PIECES



## LED LIGHTING

## MAGNESIUM ALLOY CASING

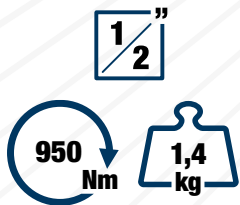

### 943 PC2 1/2"

U09430002

**Magnesium impact wrench with LED - extra compact**

#### TECHNICAL CHARACTERISTICS

Square drive	1/2"	Recommended air pressure	6,2 bar
Bolt capacity	M16	Sound level	95±3 dB(A)
Max torque	950 Nm	Sound power	107±3 dB(A)
Torque in use (Nm min-Max)	200÷270 Nm	Vibrations	3,9 m/s <sup>2</sup>
Strokes per minute	1400	Air inlet	1/4"
Free speed	10.000 rpm	Ø internal hose	10 mm
Average air consumption	167 l/min	Weight	1,4 kg

## ALUMINIUM BODY

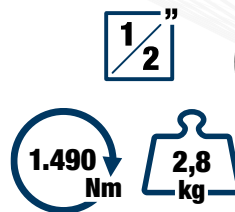

### 928 AC1 1/2"

U09280014

**Aluminium impact wrench**

#### TECHNICAL CHARACTERISTICS

Square drive	1/2"	Sound level	90 ±3 dB(A)
Bolt capacity	M16	Sound power	101 ±3 dB(A)
Max torque	1.490 Nm	Vibrations	5,2 m/s <sup>2</sup>
Torque in use (Nm min-Max)	135÷380 Nm	Air inlet	1/4"
Strokes per minute	1.120	Ø internal hose	10 mm
Free speed	6.500 rpm	Weight	2,8 kg
Average air consumption	147 l/min		
Recommended air pressure	6,2 bar		

## TITANIUM ALLOY CASING

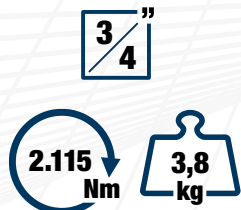

### 942 PD1 3/4"

U09420004

**Impact wrench (Titanium structure)**

#### TECHNICAL CHARACTERISTICS

Square drive	3/4"	Recommended air pressure	6,2 bar
Bolt capacity	M27	Sound level	97,8±3 dB(A)
Max torque	2.115 Nm	Sound power	108,8±3 dB(A)
Torque in use (Nm min-Max)	500÷800 Nm	Vibrations	5,06 m/s <sup>2</sup>
Strokes per minute	950	Air inlet	3/8"
Free speed	5.300 rpm	Ø internal hose	10 mm
Average air consumption	200 l/min	Weight	3,8 kg

## ALUMINIUM BODY

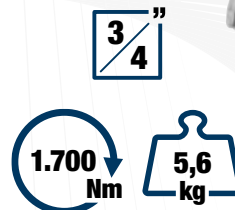

### 928 D1 3/4"

U09280015

**Aluminium impact wrench**

#### TECHNICAL CHARACTERISTICS

Square drive	3/4"	Recommended air pressure	6,2 bar
Bolt capacity	M24	Sound level	98,4±3 dB(A)
Max torque	1.700 Nm	Sound power	109,4±3 dB(A)
Torque in use (Nm min-Max)	500÷1.050 Nm	Vibrations	9,1 m/s <sup>2</sup>
Strokes per minute	790	Air inlet	3/8"
Free speed	5.700 rpm	Ø internal hose	13 mm
Average air consumption	193 l/min	Weight	5,6 kg

## COMPOSITE MATERIAL FRAME

## SOFT-TOUCH BIMATERIAL GRIP



**LIGHT AND POWERFUL**  
weighs a 20% less than a standard model



## 942 PE1 1"

U09420005

### Impact wrench (composite material frame)

#### TECHNICAL CHARACTERISTICS

Square drive	1"
Bolt capacity	M38
Max torque	3.390 Nm
Torque in use (Nm min-Max)	203÷1.627 Nm
Strokes per minute	900
Free speed	5.000 rpm
Average air consumption	400 l/min
Recommended air pressure	6,2 bar
Sound level	100,9 ±3 dB(A)
Sound power	111,9 ±3 dB(A)
Vibrations	10,6 m/s <sup>2</sup>
Air inlet	1/2"
Ø internal hose	19 mm
Weight	6,8 kg

## ALUMINIUM BODY



## 910 E1 1"

U09100020

### Aluminium impact wrench

#### TECHNICAL CHARACTERISTICS

Square drive	1"
Bolt capacity	M33
Max torque	4.068 Nm
Torque in use (Nm min-Max)	850÷1.300 Nm
Strokes per minute	720
Free speed	4.500 rpm
Average air consumption	243 l/min
Recommended air pressure	6,2 bar
Sound level	102 ±3 dB(A)
Sound power	113 ±3 dB(A)
Vibrations	15,2 m/s <sup>2</sup>
Air inlet	1/2"
Ø internal hose	13 mm
Weight	10,3 kg

# Air tools and accessories

152  
mm

5  
mm

105  
l/min

COMPACT  
221 mm



920 AN1  
U09200011

**Roto-orbital sander (orbit 5 mm)**

#### TECHNICAL CHARACTERISTICS

Power	0,19 Kw
Ø Pad capacity	Ø 152 mm
Orbit	5 mm
Free speed	10.000 rpm
Average air consumption	105 l/min
Recommended air pressure	6,2 bar
Sound level	78,9±3 dB(A)
Sound power	79,9±3 dB(A)
Vibrations	11,8 m/s <sup>2</sup>
Air inlet	1/4"
Ø hose size	10 mm
Weight	0,8 kg



125  
mm

750 W

12.000  
Rpm

921 A4  
U09210012

**Angle grinders**

#### TECHNICAL CHARACTERISTICS

Disk diameter	Ø 125 mm
Ø disk connection	Ø 24 mm
Power	0,75 Kw
Free speed	12.000 rpm
Average air consumption	120 l/min
Recommended air pressure	6,2 bar
Sound level	86±3 dB(A)
Sound power	94±3 dB(A)
Vibrations	2,5 m/s <sup>2</sup>
Air inlet	1/4"
Weight	1,9 Kg



1/2"

136  
Nm

1,2  
kg

260 mm



913 PC2 1/2"  
U09130017

**Impact ratchet**

#### TECHNICAL CHARACTERISTICS

Square drive	1/2"	Sound level	99±3 dB(A)
Bolt capacity	M10	Sound power	110±3 dB(A)
Max torque	136 Nm	Vibration	9,1 m/s <sup>2</sup>
Free speed	280 rpm	Air inlet	1/4"
Average air consumption	113 l/min	Ø hose size	10 mm
Recommended air pressure	6,2 bar	Weight	1,2 kg

16 m cable  
Ø 10 mm

939 C1  
U09390004

**Air hose reel  
10 mm**

#### TECHNICAL CHARACTERISTICS

Hose length	16 m
Ø internal hose	10 mm
Max pressure	15 bar
Output threaded male connector	3/8"
Dimensions (bracket included)	450x400x230 mm
Weight	8 kg





## AIR GRINDERS RANGE

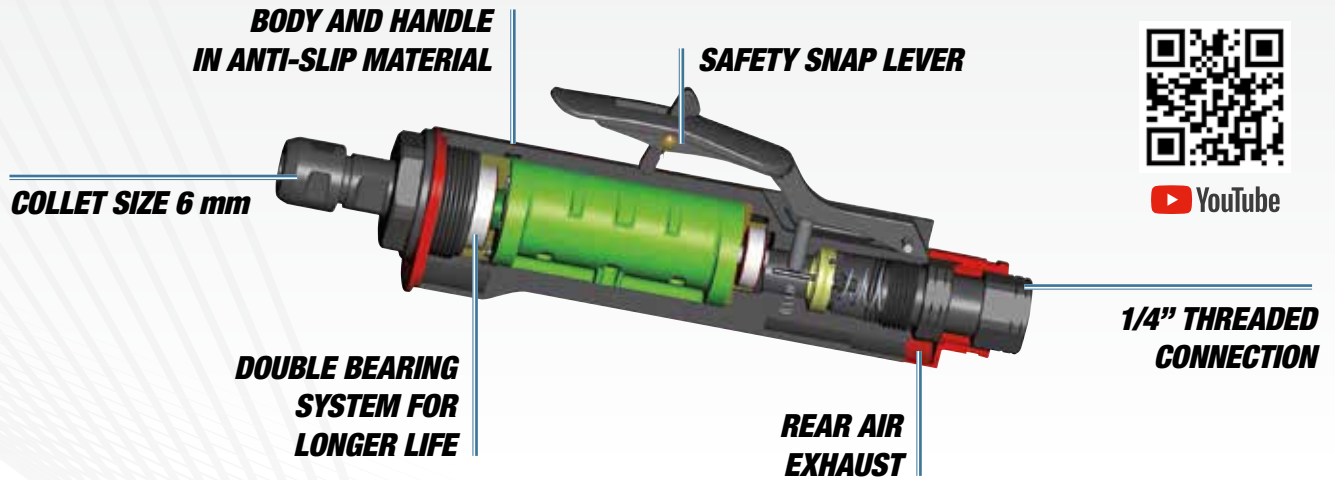

YouTube

**30.000 Rpm**



**922 B1**  
**U09220001**

**Straight grinder - 0.3 CV (220 W)**

**TECHNICAL CHARACTERISTICS**

Average air consumption	76 l/min	Vibrations	2,42 m/s <sup>2</sup>
Recommended air pressure	6,2 bar	Air inlet	1/4"
Sound level	84,8±3 dB(A)	Ø hose size	10 mm
Sound power	99,5±3 dB(A)	Weight	440 g

**23.000 Rpm**



**922 BP1**  
**U09220004**

**90° Angle grinder - 0.3 CV (220 W)**

**TECHNICAL CHARACTERISTICS**

Average air consumption	76 l/min	Vibrations	4,54 m/s <sup>2</sup>
Recommended air pressure	6,2 bar	Air inlet	1/4"
Sound level	85,9±3 dB(A)	Ø hose size	10 mm
Sound power	96,9±3 dB(A)	Weight	555 g

**28.000 Rpm**



**922 BL1**  
**U09220003**

**Long anvil straight grinder - 0.3 CV (220 W)**

**TECHNICAL CHARACTERISTICS**

Average air consumption	76 l/min	Vibrations	2,86 m/s <sup>2</sup>
Recommended air pressure	6,2 bar	Air inlet	1/4"
Sound level	83,3±3 dB(A)	Ø hose size	10 mm
Sound power	94,3±3 dB(A)	Weight	664 g



**16**  
PIECES

**1/2"**

**1/2"** **5/16"**

$\leftrightarrow$  210  
 $\updownarrow$  60  
mm  $\nearrow$  130

## 687 1/2" C16

U06870100



Assortment with **IMPACT** bits in ABS case

DESCRIPTION	ITEM/SIZE	PCS.
Impact bit-holder sockets	685 6 1/2	1
Impact bit-holder sockets	685 8 5/16	1
Impact bits for hexagonal screws - 1/2" connection	687 E 6-7-8-10-12-14	6
Impact bits for TORX® screws - 1/2" connection	687 TX T30-T40-T45-T50-T55	5
Impact bits for PHILLIPS® screws - 5/16" connection	686 PH 2-3-4	3



**16**  
PIECES

**1/2"**

$\leftrightarrow$  375  
 $\updownarrow$  80  
mm  $\nearrow$  186

## 235 1/2" M/C16

U02359285



Assortment with **IMPACT** hexagonal sockets in modular box

DESCRIPTION	ITEM/SIZE	PCS.
Impact hexagonal sockets	235 1/2 M 10-12-13-14-15-16-17-18-19-21-22-24-27-30-32 mm	15
Lock pins	235 MCA/4-6	2
Safety rings	235 MDA/4-6	2
Impact extensions	236 1/2 M/125	1



**6**  
PIECES

**3/4"** **7/8"**

$\leftrightarrow$  210  
 $\updownarrow$  60  
mm  $\nearrow$  130

## 688 3/4" MD6

U06880010



Assortment with **IMPACT** bits in ABS case

DESCRIPTION	ITEM/SIZE	PCS.
Holder for impact bits	685 B 1 7/8	1
Impact bits for hexagonal screws - 7/8" connection	688 E 12-17-19-22-24	5



**8**  
PIECES

**3/4"**

$\leftrightarrow$  375  
 $\updownarrow$  80  
mm  $\nearrow$  186

## 235 3/4" M/C8

U02359286



Assortment with short hexagonal impact sockets

DESCRIPTION	ITEM/SIZE	PCS.
Impact hexagonal sockets	235 3/4" M 21-22-24-27-30-32-36-41 mm	8

## IMPACT SOCKETS 235 MB



**1/2"**  
**10**  
PIECES

→ 190  
↓ 58  
mm ↗ 144



**1/2"**

**1/2"**

**22**  
PIECES

→ 415  
↓ 92  
mm ↗ 283

### 235 1/2" MB/C10 U02350530

Assortment with short hexagonal impact sockets

DESCRIPTION	ITEM/SIZE	PCS.
Short impact hexagonal sockets	235 1/2" M 10-11-12-13-14-15-16-17-18-19	10

### 236 KE/C22 U02360900

Assortment with short hexagonal impact sockets, extension wrench and impact bits

DESCRIPTION	ITEM/SIZE	PCS.
Short impact hexagonal sockets	235 1/2" MB 13-14-15-16-17-18-19	7
Bit-holder chain extension in Aluminium	236 KE 1/2"	1
Impact bits for hexagonal screws - 1/2" connection	687 E 5-6-8-10-12-14	6
Impact bits for TORX® screws - 1/2" connection	687 TX T25-T27-T30-T40-T45-T50-T55	7
Adapter for impact sockets	236 KEADP	1

USE WITH RATCHET OR  
IMPACT WRENCH

### 236 K for sockets



YouTube



YouTube

### 236 KE for bits

GREAT ACCESSIBILITY  
HEAD DIMENSIONS AS A RATCHET\*.



**39 mm**

\*Comparison with 1/2" ratchet.

MINIMUM SIZE  
DIRECT COUPLING FOR  
IMPACT BITS.



Integrated  
spring steel ring.

### 236 K

**1/2"** **1/4"**

Chain extension in Aluminium for sockets

CODE	□	L	H	📏
U02360700	1/2"	340 mm	39 mm	1,1 kg
U02360698	1/4"	260 mm	27 mm	300 g

### 236 KE

**1/2"** **1/2"** **1/4"** **1/4"**

Bit-holder chain extension in Aluminium

CODE	□	◇	L	H	📏
U02360705	1/2"	1/2"	340 mm	24 mm	1,1 kg
U02360710	1/4"	1/4"	260 mm	19 mm	300 g



Join our channel

@USAGexport

Tutorial video,  
new products  
and much more!

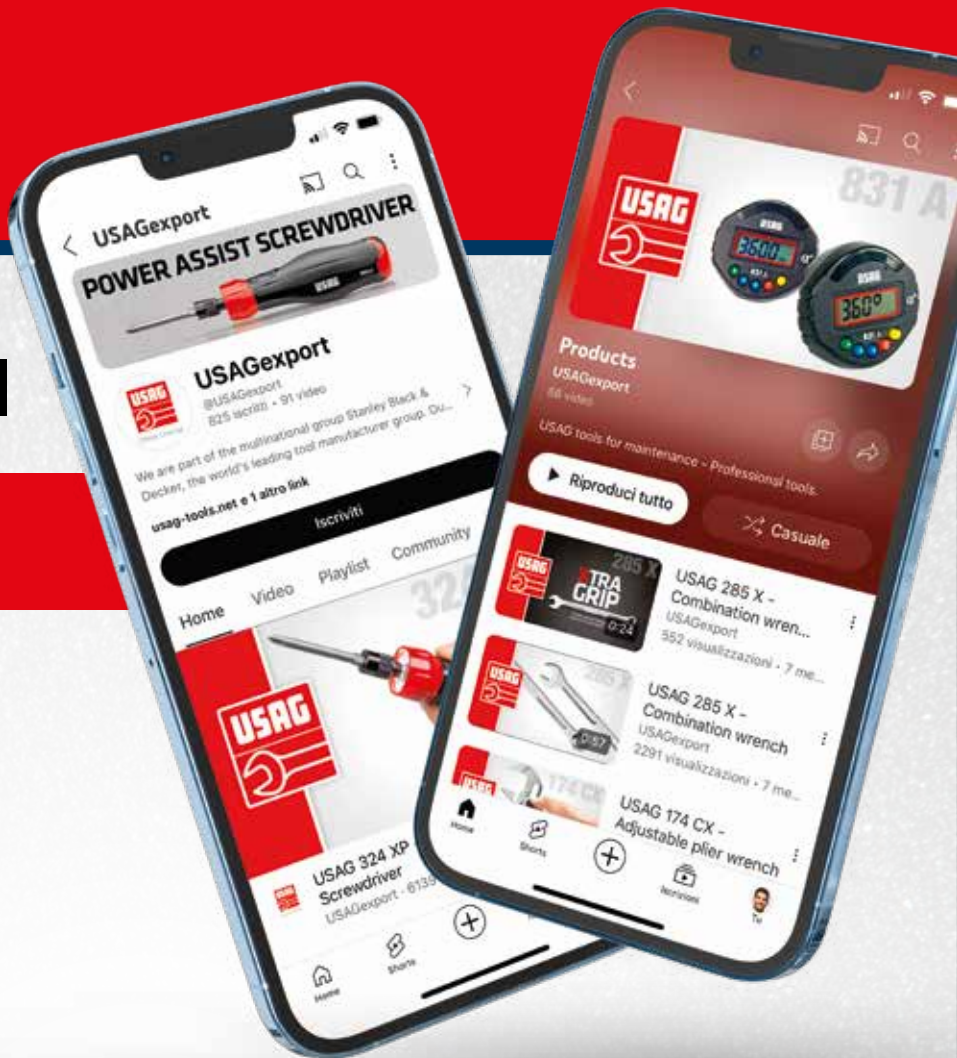

Do you need support from us?

Go to our website:



[usag.it/en/contacts/support](https://usag.it/en/contacts/support)



Promotion valid till 31/03/2025 while stocks last.

The images shown in this catalogue are not binding.

Stanley Black & Decker italia S.r.l. reserves the right to change the technical characteristics of its products at any time.



Stanley Black & Decker Italia S.r.l.

Via Volta, 3 - 21020 - Monvalle (VA)  
Tel. +39 0332 790 111 - info.mv@usag.it

[usag-tools.net](https://usag-tools.net)

